

## TEMP / HUMIDITY TRANSDUCER

For Additional Information See HU-226 Data Sheet

### HUMIDITY TRANSDUCER SPECIFICATIONS

- Accuracy\*:** ± 2% / ± 3% RH  
**Range:** 0-100% RH  
**Hysteresis:** ± 1%  
**Supply Voltage:** 12-40 VDC  
 12-35 VAC (VDC output units only)  
**Compensated Temp Range:** -30°F to 130°F (-35°C to 55°C)  
**Load Impedance:** 3K ohms max. at 40 VDC (mA output units)  
 1K ohms min. (VDC output units)

\* Includes non-linearity and non-repeatability

### THERMISTOR SENSOR SPECIFICATIONS

- Interchangeability:** ± 0.2°C  
**Heat Dissipation:** 3.0 mW/°C  
**R/T Characteristics:** Refer to TI.700-11 (See Temperature Sensor section)  
**Operating Temp Range:** -30°F to 130°F (-35°C to 55°C)  
**Conformance:** EMC Standards EN50082-1(1992)  
 EN55014(1993)/EN60730-1(1992)

### PLATINUM RTD SENSOR SPECIFICATIONS

- Accuracy:** 0.12% at 0°C  
**Resistance:** 100 or 1,000 ohm at 0°C  
**Standard:** DIN 43760  
**Heat Dissipation:** 3.0 mW/°C  
**R/T Characteristics:** Refer to TI.700-11 (See Temperature Sensor section)  
**Operating Temp Range:** -30°F to 130°F (-35°C to 55°C)  
**Conformance:** EMC Standards EN50082-1(1992)  
 EN55014(1993)/EN60730-1(1992)

### GENERAL SPECIFICATIONS

- Environmental:** 10-90%RH Non-Condensing  
**Enclosure:** 18 Ga C.R. Steel NEMA 4 (IP-65)  
**Finish:** Baked on enamel - PMS2GR88B  
**Termination:** Unpluggable screw terminal block  
**Wire Size:** 12 Ga maximum  
**Weight:** Duct Mount: 1.0 lbs. (.45 kg)

### ORDERING INFORMATION - HU-226-

ACCURACY	OUTPUT	TEMP SENSOR
± 2%	mA (4-20 mA 2-wire)	1 100 ohm Platinum RTD
		2 1,000 ohm Nickel RTD (5,000 PPM)
± 3%	VDC (0-5 VDC/0-10 VDC field selectable)	3 1,000 ohm Platinum RTD
		4 1,000 ohm Nickel RTD (6,000 PPM)
		5 1,000 ohm Balco RTD
		7 10,000 ohm NTC Thermistor (Type III)
		8 10,000 ohm NTC Thermistor (Carel)
		10 3,000 ohm NTC Thermistor
		12 10,000 ohm NTC Thermistor (Type II)
		13 5,000 ohm NTC Thermistor
		14 1,035 ohm Silicon PTC
		15 100,000 ohm NTC Thermistor
		17 20,000 ohm NTC Thermistor
		18 2,252 ohm NTC Thermistor
		21 1,800 ohm NTC Thermistor

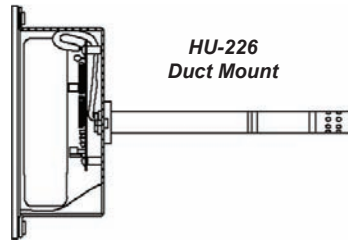

Ex: HU-226-2-mA-3 - Temp/Humidity Transducer, ±2%RH accuracy with 4-20 mA output and 1,000-ohm Platinum RTD.

For Resistance vs. Temperature Tables, please refer to TI.700.11

### INSTALLATION

**Inspection** Inspect the package for damage. If damaged, notify the appropriate carrier immediately. If undamaged, open the package and inspect the device for obvious damage. Return damaged products.

- Requirements**
- Tools (not provided)
    - Digital Volt-ohm Meter (DVM)
    - Appropriate screwdriver for mounting screws
    - Appropriate drill and drill bit for mounting screws
  - Appropriate accessories
  - Two #8 self-tapping mounting screws (not provided)
  - Training: *Installer must be a qualified, experienced technician*

- Warning:**
- Do not use on oxygen service, in an explosive/hazardous environment, or with flammable/combustible media.
  - Disconnect power supply before installation to prevent electrical shock and equipment damage.
  - Make all connections in accordance with the job wiring diagram and in accordance with national and local electrical codes. Use copper conductors only.



- Caution:**
- Use electrostatic discharge precautions (e.g., use of wrist straps) during installation and wiring to prevent equipment damage.
  - Avoid locations where severe shock or vibration, excessive moisture or corrosive fumes are present. NEMA Type 4 housings are intended for outdoor use primarily to provide a degree of protection against wind-blown dust, rain, and hose-directed water.
  - Do not exceed ratings of the device.





**TEMP / HUMIDITY TRANSDUCER**

**Mounting** HU-226 (DUCT) - Refer to **Figure 6** for mounting dimensions.

1. Drill 5/8" hole in appropriate location.
2. Mount transducer on a vertical surface with two #8 self-tapping screws (*not provided*).
3. Pull wires through knockout and make necessary connections (*see wiring diagrams*).
4. Replace cover and tighten Philips screws.

**Wiring** Use maximum 12 AWG wire for wiring terminals. Refer to **Figures 1, 2, 3, & 4** for wiring information and **Figure 5** for dip switch designations.

***mA Output***

**Wiring HU-226 Units with mA Output**

*HU-226 Humidity Transducer with mA Output*

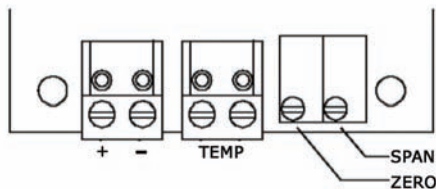

HU-226 humidity transducers are 4-20 mA output units powered with a 12-40 VDC supply.

The following describes the proper wiring of these humidity and temp sensors with mA output:

**HUMIDITY SENSOR:**

1. Remove the terminal block by carefully pulling it off the circuit board.
2. Locate the [+] and [-] terminal markings on the board.
3. Attach the supply voltage to the [-] lead.
4. Connect the 4-20 mA output ([-] terminal) to the controller's input terminal.
5. Ensure that the power supply common is attached to the common bus of the controller.
6. Re-insert the terminal block to the circuit board and apply power to the unit.
7. Check for the appropriate output signal using a DVM set on DC milliamps connected in series with the [-] terminal.

**TEMP SENSOR:**

1. Remove the terminal block by carefully pulling it off the circuit board.
2. Use shielded 18-22 AWG wire to connect temp sensor as shown in **Figures 1 & 2**.

**TYPICAL APPLICATIONS (wiring diagrams)**

**Figures 1 & 2** illustrate typical wiring diagrams for the HU-226, 4-20 mA, two-wire humidity transducers.

**Figure 1 - Wiring for mA Output Humidity Transducer with External DC Power Supply**

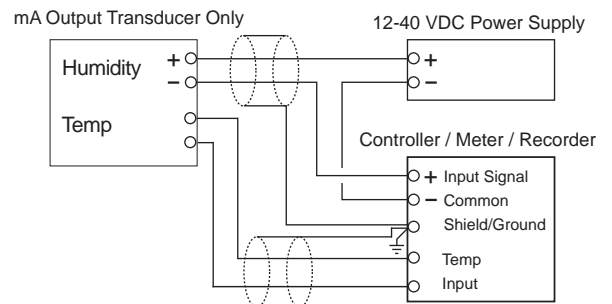

**Figure 2 - Wiring for mA Output Humidity Transducer where Controller or Meter has Internal DC Power Supply**

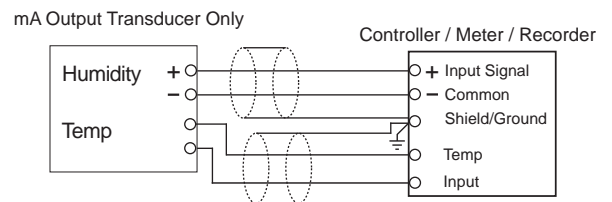

**Caution:** If you are using grounded AC, the hot wire must be on the [+] terminal. Also, if you are using a controller without built-in isolation, use an isolation transformer to supply the HU-226 transducer.



**Caution:** This product contains a half-wave rectifier power supply and must not be powered off transformers used to power other devices utilizing non-isolated full-wave rectifier power supplies.

**Caution:** When multiple units are powered from the same transformer, damage will result unless all 24G power leads are connected to the same power lead on all devices. It is mandatory that correct phasing be maintained when powering more than one device from a single transformer.

**TEMP / HUMIDITY TRANSDUCER**

**VDC Output**

**Wiring HU-226 Units with VDC Output**

*HU-226 Humidity Transducer with VDC Output*

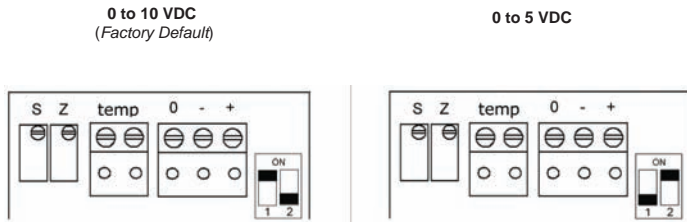

HU-226 humidity transducers with VDC output are field selectable 0-5 VDC or 0-10 VDC output and can be powered with either 12-40 VDC or 12-35 VAC.

The following describes the proper wiring of these humidity transducers with VDC output:

**HUMIDITY SENSOR:**

1. Remove the terminal block by carefully pulling it off the circuit board.
2. Locate the [+], [-] and [O] terminal markings on the board.
3. Attach the power wires to the [+ ] and [-] terminals. The [-] terminal is also the negative output terminal.
4. Connect the [O] terminal, which is the positive VDC output terminal, to the controller's input terminal.
5. Re-insert the terminal block to the circuit board and apply power to the unit.
6. Check the appropriate VDC output using a voltmeter set on DC volts across the [O] and [-] terminals.

**TEMP SENSOR:**

1. Remove the terminal block by carefully pulling it off the circuit board.
2. Use shielded 18-22 AWG wire to connect temp sensor as shown in **Figures 3 & 4**.

**TYPICAL APPLICATIONS (wiring diagrams)**

**Figures 3 & 4** illustrate typical wiring diagrams for the HU-226, 0-5/0-10 VDC output humidity transducers.

**Figure 3 - Wiring for VDC Output when applied with External AC Supply**

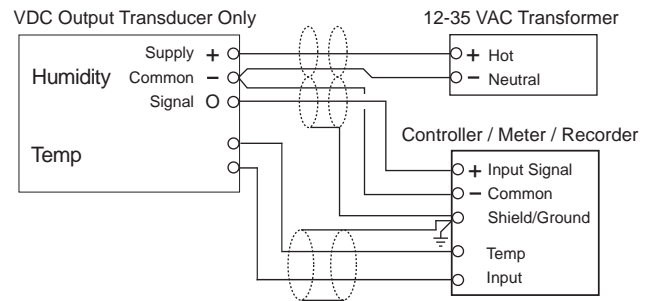

**Figure 4 - Wiring for VDC Output when applied with External DC Power Supply**

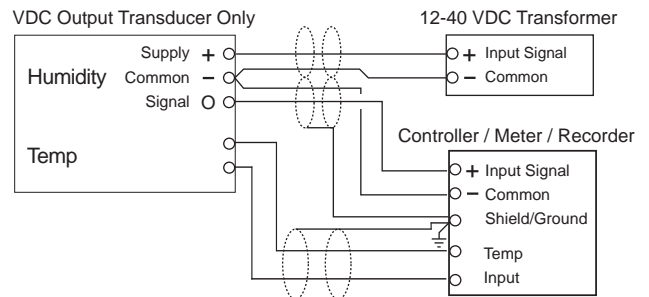

**Figure 5 - Dip Switch Settings for HU-226 VDC Output**

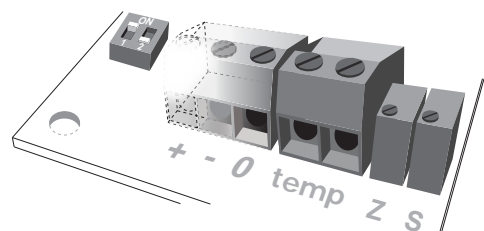
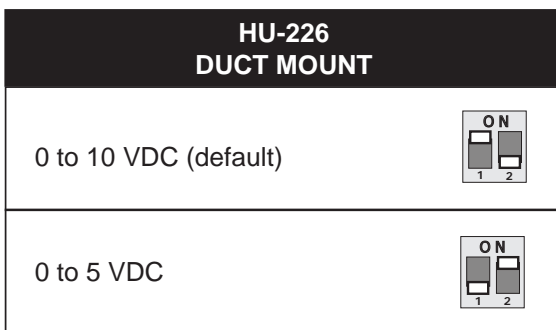



**TEMP / HUMIDITY TRANSDUCER**

- CHECKOUT**
1. Verify that the unit is mounted in the correct position.
  2. Verify appropriate input signal and supply voltage.



**CAUTION:** *Never connect 120 VAC to these transducers. Never connect AC voltage to a unit intended for DC supply.*

3. Verify appropriate configuration range.

**Transducer Operation**

**NOTE:** *The HU-226 is a highly accurate device. For applications requiring a high degree of accuracy, the use of laboratory-quality meters and gauges are recommended.*

**CALIBRATION** All units are factory calibrated to meet or exceed published specifications. If field adjustment is necessary, follow the instructions below.

**Calibration of HU-226 mA/VDC Humidity Transducer**

Field calibration instructions are provided with the following precautions and advice:

1. Do not verify comparative RH with a sling Psychrometer. There are far too many variables which induce errors into this process. New HU-226 RH transducers are already supplied with calibration.
2. Recalibration must be done in a controlled environment. Relative humidity must be held stable while making any adjustment.
3. Verify the output from the device directly with calibrated instrumentation and verify the RH with calibrated instrumentation, (NOT A CONTROLLER OUTPUT). With the correct power applied and only a meter connected to the output of the transducer, ensure that the output is proportional to the true RH.

**4. A) SINGLE POINT CALIBRATION:**

**[NOTE: SELECT EITHER OPTION 1 OR OPTION 2, BUT NOT BOTH.]**

Option 1. Select a controlled humidity environment between 10 & 40% R.H. Insure humidity is stable and adjust zero trimmer (Z).

Option 2. Select a controlled humidity environment between 40 & 70% R.H. Insure humidity is stable and adjust span trimmer (S).

**B) TWO-POINT CALIBRATION:** Select a controlled humidity environment between 10 & 40% RH Insure humidity is stable and adjust zero trimmer (Z). Then select a controlled humidity environment between 70 & 75% RH. Insure humidity is stable and then adjust span trimmer (S).

**MAINTENANCE** Regular maintenance of the total system is recommended to assure sustained optimum performance.

**FIELD REPAIR** None. Replace with a functional unit.

**WARRANTY** See Data Sheet for additional information.

**DIMENSIONAL DATA**

**Figure 6 - HU-226 Humidity Transducer Dimensions shown in inches and millimeters (mm).**

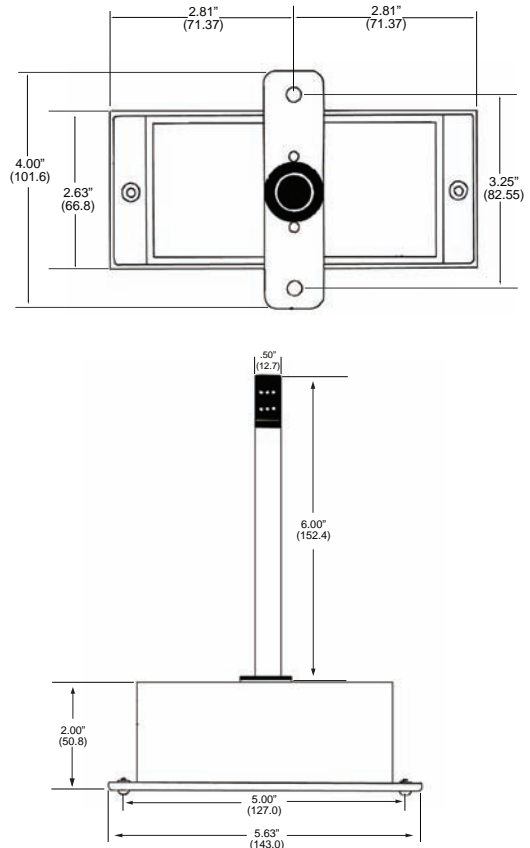

For Technical / Application Assistance call your nearest office



**8189 Century Boulevard • Minneapolis, MN 55317-8002 • USA**  
**800-843-5116 • 952-556-4900 • Fax 952-556-4997**  
**sales@mamacsys.com • www.mamacsys.com**

EUROPE
Baird House, Units 6 & 7 Dudley Innovation Centre Pensnett Estate • Kingswinford West Midlands • DY6 8XZ United Kingdom 01384-271113 • Fax 01384-271114

AUSTRALIA
4 Arminger Court, Unit 2 Holden Hill • S.A. 5088 Australia 08-8359-4333 • Fax 08-8395-4433

ASIA
No. 22 Lorong 21A Geylang #11-02 Prosper Industrial Building Singapore • 388421 656-3927273 • Fax 656-3927276

CANADA
155 McIntosh Drive, Unit 5 Markham • Ontario • L3R 0N6 Canada 905-474-9215 • Fax 905-474-0876

MAMAC Systems, Inc., reserves the right to change any specifications without notice to improve performance, reliability, or function of our products.