

Low Pressure Transducer

Model PR-274/275



- **100% solid state, micro-machined, glass-on-silicon, ultra-stable capacitance sensor**
- **As low as $\pm 0.05''$ wc (± 12.5 pa)**
- **Can resolve less than $0.00001''$ wc (0.00025 pa)**
- **Up to 10 PSID overpressure without zero shift**
- **Up to 6 field selectable ranges in one unit**
- **Wide 12-40 VDC/12-35 VAC unregulated supply voltage**
- **Two temperature compensated output versions, 4-20 mA 2-wire or field selectable 0-5 VDC/0-10 VDC**
- **Non-interacting zero and span trimmers**
- **NIST traceable calibration**
- **Two rugged steel enclosure types NEMA 4 (IP-65) or panel mount for ease of installation**
- **Short circuit and reverse polarity protected**
- **Conforms to EMC standards EN50082-1/EN55014/EN60730-1**

The PR-274/275 incorporates a new micro-machined glass-on-silicon (Gl-Si) capacitance sensor. This technology revolutionizes very low pressure measurement. Temperature related zero drift, calibration shift due to overpressure, non-repeatability, non-linearity, and extremely low pressure sensitivity have been some of the problems which have plagued the controls industry. The PR-274/275 with the new Gl-Si technology not only addresses all of the above shortcomings, but for the first time offers a reliable, accurate means to measure and control building/room pressure, air flow, duct pressure, filter pressure drop, or any other extremely low pressure application. Up to six field selectable direct or compound ranges, two enclosure types, field selectable outputs, fully temperature compensated NIST traceable accuracy, non-interacting zero and span adjustments, short circuit and reverse polarity protected output, and a liberal two year warranty are some of the features which make the PR-274/275 the industry's highest performance, ultra-stable, low pressure transducer.

MAMAC SYSTEMS®

8189 Century Boulevard • Minneapolis, MN 55317-8002 • USA
800-843-5116 • 952-556-4900 • Fax 952-556-4997
sales@mamacsys.com • www.mamacsys.com

Baird House, Units 6&7
Pensnett Estate • Kingswinford
West Midlands • DY6 7YA • United Kingdom
01384-271113 • Fax 01384-271114

4 Arminger Court, Unit 2
Holden Hill • S.A. 5088 • Australia
08-8395-4333 • Fax 08-8395-4433

155 McIntosh Drive, Units 5&6 • Markham
Ontario • L3R 0N6 • Canada
905-474-9215 • Fax 905-474-0876

No. 22 Lorong 21A Geylang # 11-02
Prosper Industrial Building
Singapore • 388421
656-3927273 • Fax 656-3927276

PR-274/275

The PR-274/275 incorporates sophisticated integrated circuits to not only provide a high level, fully conditioned and temperature compensated output, but also to offer field selectable flexibility which was unheard of in the industry. The PR-274/275 offers up to six field selectable pressure ranges in one unit. In this way, a customer does not need to know the exact pressure range prior to selection. By merely knowing the application, a unit may be selected and then later field configured for the desired pressure range. With fixed range units, in case of engineering error or incorrect selection, the only solution is expensive field recalibration or time consuming product exchange or replacement. Similarly, numerous units have to be kept in stock as spares to cover all ranges in case of field failure. The PR-274/275 with the field selectable pressure ranges in a particular application thereby eliminating the need to stock numerous fixed range units. (For a complete listing of all the ranges available, please see the ordering information section on page three.)

On VDC output units, two additional field selectable options are available: dual outputs 0-5 or 0-10 VDC, and dual unregulated supply voltages 12-35 VAC or 12-40 VDC. By merely moving a shorting plug, one can select the desired output for the specific application. As far as supply voltage is concerned, the unit automatically configures for AC or DC and no field selection is necessary. Another feature is that the output is fully protected from short circuit to ground, or if the supply voltage is applied by mistake to the output. Past experience demonstrates that field related wiring problems do occur. Instead of denying this fact, the protection circuit is designed in to ensure trouble-free start-up. The VDC output unit is also designed to handle low impedance circuits. In fact, the unit can drive up to 1k ohms minimum. In this way, multiple controllers, indicators, or other devices can be paralleled to the output without performance degradation.

The mA output units can function over a wide unregulated supply voltage range: 12-40 VDC without any effect on calibration or performance. The unit has reverse polarity protection built in. As a result, it is next to impossible to damage the unit by mis-wiring. By using sophisticated low drop-out voltage regulators and CMOS integrated circuits, the mA output unit can drive very high output impedance.

In fact, with only 12 VDC supply, the unit can drive 200 ohms. At 40 VDC, the unit is capable of handling up to 1600 ohms load. In this way, the output loop can be tied in series to multiple controllers, indicators, and other devices without degrading the performance.

Automated NIST traceable pressure controllers and precision Barocel® pressure sensors are utilized to calibrate and certify the PR-274/275 transducers. Calibration data on each unit is archived digitally for SPC and QC purposes. All automated calibration systems are networked and data is available on-line to numerous individuals at the same time. In this way, extremely high standards of quality and calibration integrity are maintained. Each unit is individually temperature compensated in an environmental chamber. The temperature compensation data is also digitized and archived for future reference purposes. Compensating each unit individually ensures that published specifications are adhered to.

Due to low mass of the micro-machined capacitance GI-Si sensor, the mounting orientation error for ranges higher than 1.0"wc (250 pa) is negligible. For extremely low ranges, if the unit is installed as indicated on the label, there should be no orientation error. However, due to space limitation, if the unit cannot be installed in the indicated position, the error can be easily removed by merely adjusting the zero trimmer. Since the zero and span trimmers are non-interactive, adjustment to the zero should under no circumstance affect the calibration integrity of the unit including linearity and repeatability specifications across the range.

The PR-274/275 is available with two packaging options: a NEMA 4 (IP-65) fully gasketed, dust proof and splash proof enclosure, or a lightweight but rugged panel mount chassis for ease of installation with minimum space requirement in a control panel. The NEMA 4 (IP-65) enclosure has an external mounting bracket to facilitate field installation. A 1/2" (.875"/22.25mm dia.) knock-out for conduit connection is also provided. A liquid tight cable connector is also supplied if the unit is not being hard wired. Once installed, the enclosure maintains its environmental rating and protects the electronics and the sensing element from condensation, corrosive contaminants and other environmental pollutants. Both packaging options also have additional features for ease of installation, including unpluggable terminal blocks, rugged brass hose barbs, easily accessible zero and span trimmers, and conveniently located shorting plugs for field selection.

PR-274/275

Specifications:

Accuracy*: $\pm 1\%$ FS

Overpressure: 10 PSID

Supply Voltage: 12-40 VDC
12-35 VAC (VDC output units only)

Supply Current: VDC Units - 10 mA max.
mA Units - 20 mA max.

Enclosure: 18 Ga C. R. Steel NEMA 4 (IP-65)
or Panel Mount Chassis

Finish: Baked on enamel-PMS2GR88B

Compensated Temp Range: 25°F-150°F (-4°C-65°C)

T. C. Error: $\pm 0.0125\%/^{\circ}\text{F}$ (.02%/°C)

Operating Temp Range: 0°F-175°F (-18°C-80°C)

Media Compatibility: Clean dry air or any inert gas

Environmental: 10-90%RH Non-Condensing

Termination: Unpluggable screw terminal block

Wire Size: 12 Ga max.

Load Impedance: 1.6K ohms max. at 40 VDC (mA output units) 1K ohms min. (VDC output units)

Weight: Enclosure 1.0 lbs. (.45 kg),

Panel Mount: 0.5lbs. (.25 kg)

**Includes non-linearity, hysteresis and non-repeatability*

Ordering Information: PR-

	PACKAGING	RANGE	OUTPUT
274 (enclosure)	R1 ("wc)	0 TO 0.10 / -0.05 TO + 0.05	mA (4-20 mA 2 wire)
275 (panel mount)	R2 ("wc)	0 TO 1.0 / 0 TO 0.5 / 0 TO 0.25/ -0.5 TO + 0.5 / -0.25 TO + 0.25/ -0.125 TO + 0.125	VDC (0-5 VDC or 0-10VDC field selectable)
	R3 ("wc)	0 TO 5.0 / 0 TO 2.5 / 0 TO 1.25/ -2.5 TO +2.5 / -1.25 TO + 1.25/ -0.625 TO + 0.625	
	R4 ("wc)	0 TO 30 / 0 TO 15 / 0 TO 7.5/ -15.0 TO + 15.0 / -7.5 TO + 7.5/ -3.75 TO + 3.75	
	R5* (pa)	0 TO 25 / -12.5 TO + 12.5	
	R6* (pa)	0 TO 250 / 0 TO 125 / 0 TO 62.5/ -125 TO + 125 / -62.5 TO + 62.5/ -31.25 TO + 31.25	
	R7* (pa)	0 TO 1250 / 0 TO 625 / 0 TO 312.5/ -625 TO + 625 / -312.5 TO + 312.5/ -156.25 TO + 156.25	
	R8* (pa)	0 TO 7500 / 0 TO 3750 / 0 TO 1875/ -3750 TO + 3750 / -1875 TO + 1875/ -937.5 TO + 937.5	

Example: PR-274-R2-mA: Enclosure unit with R2 Range which has six (6) field selectable range options and 4-20 mA output.

PR-274/275

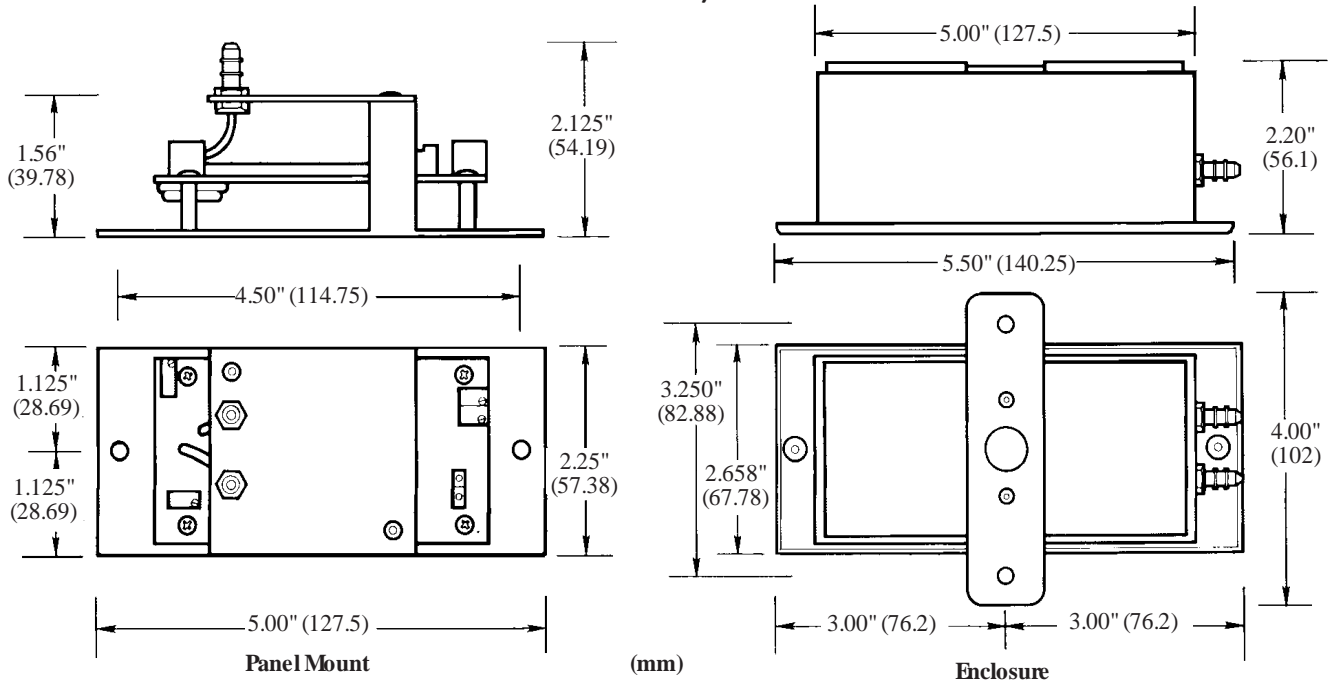

WARRANTY: MAMAC Systems, Inc. warrants its products to be free of defects in material and workmanship for a period of two (2) years from date of shipment. If a unit is malfunctioning, it must be returned to the factory for evaluation. A return authorization number (RMA) will be issued by the customer service department and this number must be written or prominently displayed on the shipping boxes and all related documents. The defective part should be shipped freight pre-paid to the factory. Upon examination by MAMAC Systems, Inc., if the unit is found to be defective, it will be repaired or replaced at no charge to the customer. However, this warranty is void if the unit shows evidence of being tampered with, damaged during installation, misapplied, misused, or used in any other operating condition outside of the unit's published specifications.

MAMAC Systems, Inc. makes no other warranties or representations of any kind whatsoever, expressed or implied, except that of title. All implied warranties including any warranty of merchantability and fitness for a particular purpose are hereby disclaimed. User is responsible to determine suitability for intended use.

LIMITATIONS OF LIABILITY: The remedies of buyer set forth herein are exclusive and the total liability of MAMAC Systems, Inc. with respect to this order, whether based on contract, warranty, negligence, indemnification, strict liability or otherwise, shall not exceed the purchase price of the product upon which liability is based. **In no event shall MAMAC Systems, Inc. be liable for consequential, incidental or special damages.** MAMAC Systems, Inc. reserves the right to change any specifications without notice to improve performance, reliability, or function of our products.

Every precaution for accuracy has been taken in the preparation of this manual, however, MAMAC Systems, Inc. neither assumes responsibility for any omissions or errors that may appear nor assumes liability for any damages that result from the use of the product in accordance with the information contained in the manual.



8189 Century Boulevard • Minneapolis, MN 55317-8002 • USA
 800-843-5116 • 952-556-4900 • Fax 952-556-4997
 sales@mamacsys.com • www.mamacsys.com

Baird House, Units 6&7
 Pensnett Estate • Kingswinford
 West Midlands • DY6 7YA • United Kingdom
 01384-271113 • Fax 01384-271114

4 Arminger Court, Unit 2
 Holden Hill • S.A. 5088 • Australia
 08-8395-4333 • Fax 08-8395-4433

155 McIntosh Drive, Units 5&6 • Markham
 Ontario • L3R 0N6 • Canada
 905-474-9215 • Fax 905-474-0876

No. 22 Lorong 21A Geylang # 11-02
 Prosper Industrial Building
 Singapore • 388421
 656-3927273 • Fax 656-3927276