

## DUCT PRESSURE TRANSDUCER

For Additional Information See PR-276 Data Sheet

### SPECIFICATIONS

- Accuracy\*:** ± 1% FS
- Overpressure:** 10 PSID
- Supply Voltage:** 12–40 VDC  
 12–35 VAC (VDC output units only)
- Supply Current:** VDC Units – 10 mA max.  
 mA Units – 20 mA max.
- Enclosure:** 18 Ga C. R. Steel NEMA 4 (IP-65)  
 6061T aluminum probe
- Finish:** Baked on enamel – PMS2GR88B
- Conformance:** EMC Standards EN50082-1(1992)  
 EN55014(1993)/EN60730-1(1992)
- Compensated Temp Range:** 25°F to 150°F (-4°C to 65°C)
- T. C. Error:** ±0.0125%/°F (.02%/°C)
- Operating Temp Range:** 0°F to 175°F (-18°C to 80°C)
- Media Compatibility:** Clean dry air or any inert gas
- Environmental:** 10–90%RH Non-Condensing
- Termination:** Unpluggable screw terminal block
- Wire Size:** 12 Ga max.
- Load Impedance:** 1.6K ohms max. at 40 VDC (mA output units)  
 1K ohms min. (VDC output units)
- Weight:** Enclosure 1.0 lbs. (.45 kg)

*\*Includes non-linearity, hysteresis and non-repeatability*

### ORDERING INFORMATION

RANGE	OUTPUT
R10 ("wc) 0 TO 5.0 / 0 TO 2.5 / 0 TO 1.25	mA (4–20 mA 2-wire)
R11 ("wc) 0 TO 15.0 / 0 TO 7.5 / 0 TO 3.75	VDC (0–5 VDC/0–10 VDC field selectable)
R12 (pa) 0 TO 1250 / 0 TO 625 / 0 TO 312.5	
R13 (pa) 0 TO 3750 / 0 TO 1875 / 0 TO 937.5	

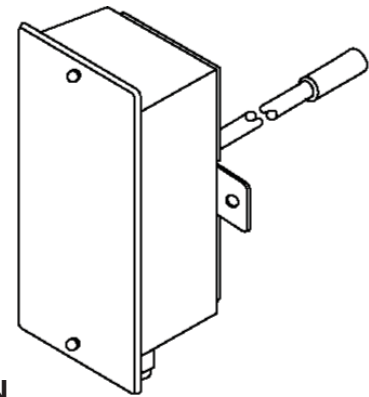

### INSTALLATION

- Inspection** Inspect the package for damage. If damaged, notify the appropriate carrier immediately. If undamaged, open the package and inspect the device for obvious damage. Return damaged products.
- Requirements**
- Tools (*not provided*)
    - Digital Volt-ohm Meter (DVM)
    - Appropriate screwdriver for mounting screws
    - Appropriate drill and drill bit for mounting screws
  - Appropriate accessories
  - Two #8 self-tapping mounting screws (*not provided*)
  - Training: Installer must be a qualified, experienced technician



#### Warning:

- Do not use on oxygen service, in an explosive/hazardous environment, or with flammable/combustible media.
- Disconnect power supply before installation to prevent electrical shock and equipment damage.
- Make all connections in accordance with the job wiring diagram and in accordance with national and local electrical codes. Use copper conductors only.



#### Caution:

- Use electrostatic discharge precautions (e.g., use of wrist straps) during installation and wiring to prevent equipment damage.
- Avoid locations where severe shock or vibration, excessive moisture or corrosive fumes are present. NEMA Type 4 housings are intended for outdoor use primarily to provide a degree of protection against wind-blown dust, rain, and hose-directed water.
- Do not exceed ratings of the device.

### Mounting

Refer to **Figure 7** for mounting dimensions.

1. Remove the transducer cover using a Phillips head screwdriver.
2. Select the mounting location.
3. Mount transducer on a vertical surface with two #8 self-tapping screws (*not provided*).
4. Pull wires through bottom of enclosure and make necessary connections.
5. Replace cover and make pneumatic connections.

### Wiring

Use maximum 12 AWG wire for wiring terminals. Refer to **Figures 1, 2, 3, & 4** for wiring information and **Figures 5 & 6** for switch designations.

*(Wiring Instructions continued on pages 2 and 3.)*



**DUCT PRESSURE TRANSDUCER**

**Wiring PR-276 Units with mA Output**

**PR-276 Duct Pressure Transducer with mA Output**

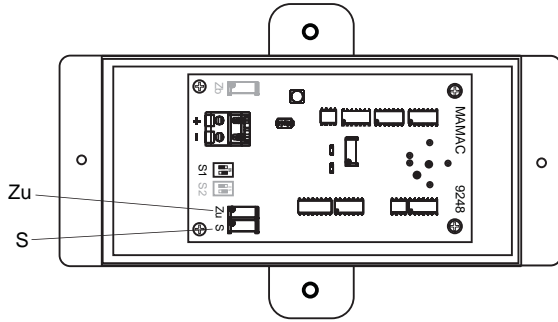

PR-276 pressure transducers with 4–20 mA output units are powered with a 12–40 VDC supply.

The following describes the proper wiring of these pressure transducers with mA output:

1. Remove the terminal block by carefully pulling it off the circuit board.
2. Locate the [+] and [-] terminal markings on the board.
3. Attach the supply voltage to the [+] lead.
4. Connect the 4–20 mA output ([-] terminal) to the controller's input terminal.
5. Ensure that the power supply common is attached to the common bus of the controller.
6. Re-insert the terminal block to the circuit board and apply power to the unit.
7. Check for the appropriate output signal using a DVM set on DC milliamps connected in series with the [-] terminal.

**Wiring PR-276 Units with VDC Output**

**PR-276 Duct Pressure Transducer with VDC Output**

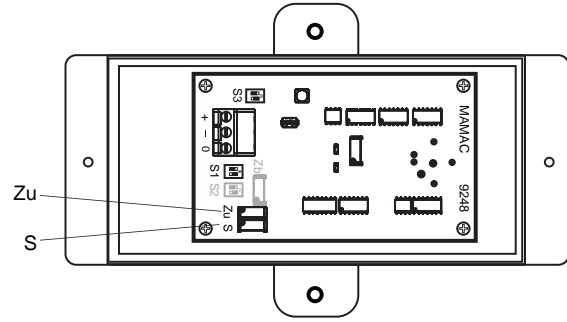

PR-276 pressure transducers with VDC output are field selectable 0–5 VDC or 0–10 VDC output and can be powered with either a 12–40 VDC or 12–35 VAC.

The following describes the proper wiring of these pressure transducers with VDC output:

1. Remove the terminal block by carefully pulling it off the circuit board.
2. Locate the [+], [-] and [0] terminal markings on the board.
3. Attach the power wires to the [+] and [-] terminals. The [-] terminal is also the negative output terminal.
4. Connect the [0] terminal, which is the positive VDC output terminal, to the controller's input terminal.
5. Re-insert the terminal block to the circuit board and apply power to the unit.
6. Check the appropriate VDC output using a voltmeter set on DC volts across the [0] and [-] terminals.

**TYPICAL APPLICATIONS (wiring diagrams)**

Figures 1 & 2 illustrate typical wiring diagrams for the PR-276 Series, 4–20 mA, two-wire output duct pressure transducers.

**Figure 1 – Wiring for mA Output Duct Pressure Transducers with External DC Power Supply**

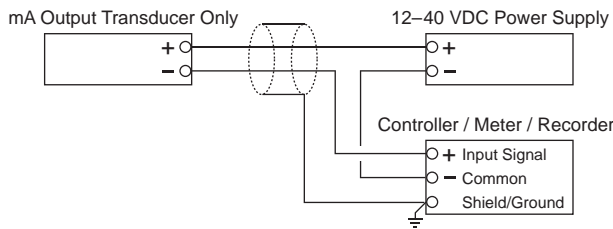

**Figure 2 – Wiring for mA Output Duct Pressure Transducers where Controller or Meter has Internal DC Power Supply**

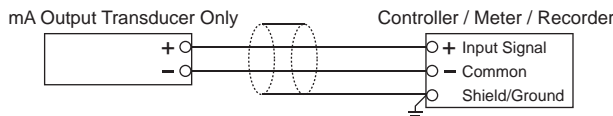

**TYPICAL APPLICATIONS (wiring diagrams)**

Figures 3 & 4 illustrate typical wiring diagrams for the PR-276, 0–5/0–10 VDC output duct pressure transducers.

**Figure 3 – Wiring for VDC Output Duct Pressure Transducers when applied with External AC Supply**

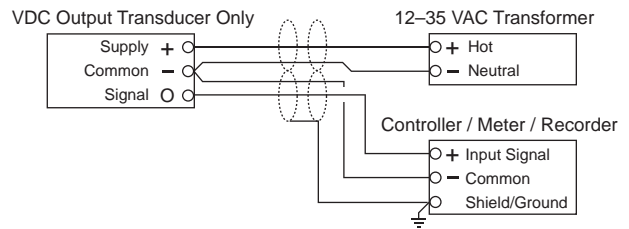

**Figure 4 – Wiring for VDC Output Duct Pressure Transducers when applied with External DC Power Supply**

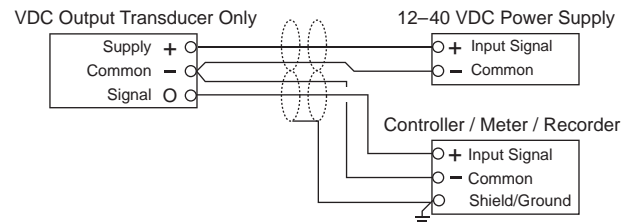

- Caution:** If you are using grounded AC, the hot wire must be on the [+] terminal. Also, if you are using a controller without built-in isolation, use an isolation transformer to supply the PR-276 transducer.
- Caution:** This product contains a half-wave rectifier power supply and must not be powered off transformers used to power other devices utilizing non-isolated full-wave rectifier power supplies.
- Caution:** When multiple PR-276 units are powered from the same transformer, damage will result unless all 24G power leads are connected to the same power lead on all devices. It is mandatory that correct phasing be maintained when powering more than one device from a single transducer.



**DUCT PRESSURE TRANSDUCER**

**mA Output**

Range Configuration:		Switch 1 (S1)
R10 / R12	0 – 5.0 "wc / 1250 pa (default)	
	0 – 2.5 "wc / 625 pa	
	0 – 1.25 "wc / 312.5 pa	
R11 / R13	0 – 15.0 "wc / 3750 pa (default)	
	0 – 7.5 "wc / 1875 pa	
	0 – 3.75 "wc / 937.5 pa	
Factory Sealed		Switch 2 (S2)

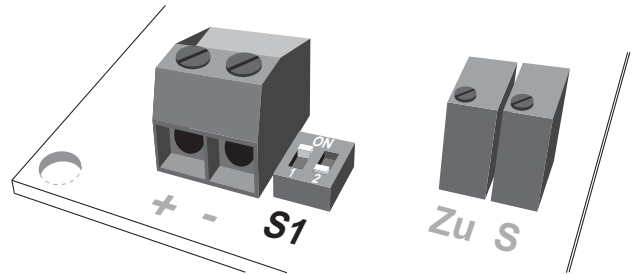
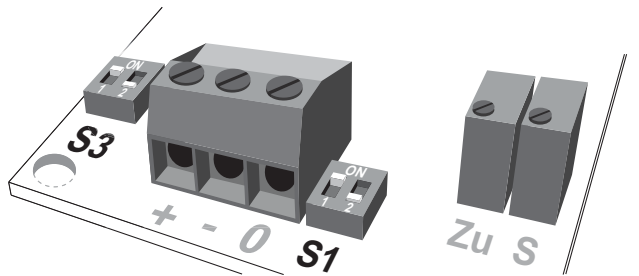

Figure 5 – Range Configurations for Pressure Transducers with mA Outputs

**VDC Output**

Range Configuration:		Switch 1 (S1)
R10 / R12	0 – 5.0 "wc / 1250 pa (default)	
	0 – 2.5 "wc / 625 pa	
	0 – 1.25 "wc / 312.5 pa	
R11 / R13	0 – 15.0 "wc / 3750 pa (default)	
	0 – 7.5 "wc / 1875 pa	
	0 – 3.75 "wc / 937.5 pa	
Factory Sealed		Switch 2 (S2)



Output Configuration:		Switch 3 (S3)
0 – 10 VDC (default)		
0 – 5 VDC		

Figure 6 – Range Configurations for Pressure Transducers with VDC Outputs



**DUCT PRESSURE TRANSDUCER**

- CHECKOUT**
1. Verify that the unit is mounted in the correct position.
  2. Verify appropriate input signal and supply voltage.



**CAUTION:** *Never connect 120 VAC to these transducers. Never connect AC voltage to a unit intended for DC supply.*

3. Verify appropriate configuration range.

**Transducer Operation**

This is a rough functional check only.

1. Adjust the pressure to obtain maximum output signal for appropriate range.
2. Output should be 20 mA or 5 or 10 VDC.
3. Adjust the pressure to obtain minimum output signal.
4. Output should be 4 mA or 0 VDC.

**NOTE:** *The PR-276 is a highly accurate device. For applications requiring a high degree of accuracy, the use of laboratory quality meters and gauges are recommended.*

**CALIBRATION** All units are factory calibrated to meet or exceed published specifications. If field adjustment is necessary, follow the instructions below.

**Calibration of PR-276 mA Units**

1. Connect terminals [+] and [-] to the appropriate power source.
2. Connect the DVM in series on the [-] terminal.
3. Apply low pressure to the unit and carefully adjust the zero trimmer [Zu] to obtain desired low output.
4. Apply high pressure to the unit and adjust span trimmer [S] to obtain the desired high output pressure.
5. Repeat steps 3 and 4 until desired calibration is achieved.

**Calibration of PR-276 VDC Units**

1. Connect terminals [+] and [-] to the appropriate power source. The [-] terminal is also the negative output terminal.
2. Connect the DVM on DC volts across [0] and [-] terminal.
3. Apply low pressure to the unit and carefully adjust the zero trimmer [Zu] to obtain desired low output.
4. Apply high pressure to the unit and adjust span trimmer [S] to obtain the desired high output pressure.
5. Repeat steps 3 and 4 until desired calibration is achieved.

**MAINTENANCE** Regular maintenance of the total system is recommended to assure sustained optimum performance.

**FIELD REPAIR** None. Replace with a functional unit.

**WARRANTY** See Data Sheet for additional information.

**DIMENSIONAL DATA**

**Figure 7 – PR-276 Duct Pressure Transducer Dimensions shown in inches and millimeters (mm).**

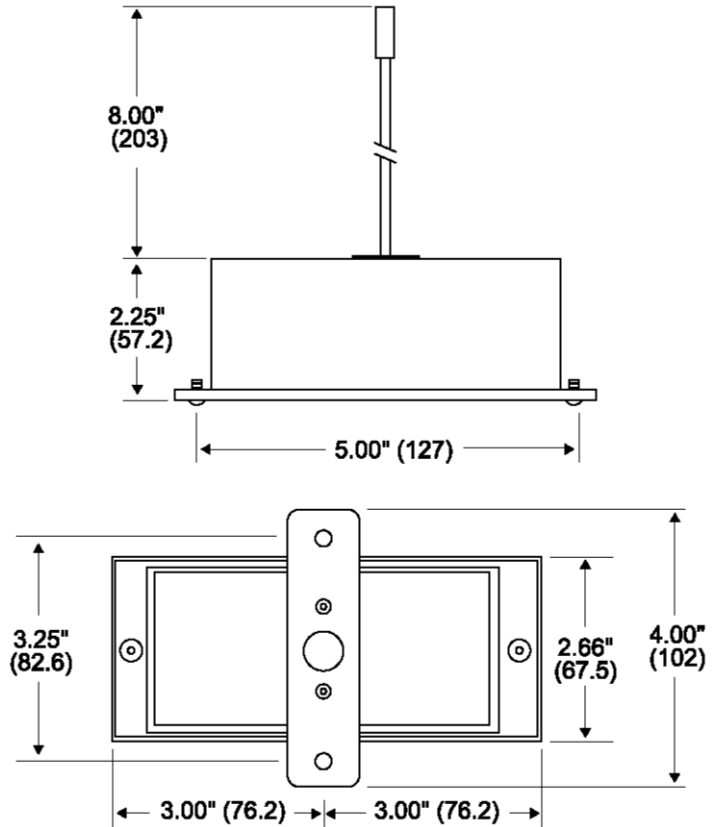

For Technical / Application Assistance call your nearest office



8189 Century Boulevard • Minneapolis, MN 55317-8002 • USA  
 800-843-5116 • 952-556-4900 • Fax 952-556-4997  
 sales@mamacsys.com • www.mamacsys.com

EUROPE
Baird House, Units 6 & 7 Dudley Innovation Centre Pensnett Estate • Kingswinford West Midlands • DY6 8XZ United Kingdom 01384-271113 • Fax 01384-271114

AUSTRALIA
4 Arminger Court, Unit 2 Holden Hill • S.A. 5088 Australia 08-8359-4333 • Fax 08-8395-4433

ASIA
No. 22 Lorong 21A Geylang #11-02 Prosper Industrial Building Singapore • 388421 656-3927273 • Fax 656-3927276

CANADA
155 McIntosh Drive, Unit 5 Markham • Ontario • L3R 0N6 Canada 905-474-9215 • Fax 905-474-0876

MAMAC Systems, Inc., reserves the right to change any specifications without notice to improve performance, reliability, or function of our products.