



8189 Century Boulevard • Minneapolis, MN 55317-8002 • USA
 800-843-5116 • 952-556-4900 • Fax 952-556-4997
 sales@mamacsys.com • www.mamacsys.com



Model TE-705
Technical Information
 TI.705-01

DUCT AVERAGING TEMPERATURE SENSORS

For Additional Information See TE-705 Data Sheet

SPECIFICATIONS

Platinum RTD Sensors:

±0.1% @ 32°F (0°C), Alpha: 385 per DIN 43760

Nickel RTD Sensors (#2):

±0.5°C @ 0°C (32°F), 5,000 PPM/K T.C.R.

Nickel RTD Sensors (#4):

±0.5°F @ 70°F (21.1°C), 6,000 PPM/K T.C.R.

Balco RTD Sensors:

±0.5°F @ 70°F (21.1°C), 4,300 PPM/K T.C.R.

Thermistor Sensors:

±0.2°C interchangeability @ 77°F (25°C)

Operating Temperature:

-40°F to 210°F (-40°C to 100°C)

Probe Material:

3/8" (9 mm) Bendable aluminum

Flange Material:

Galvanized Steel

Steel NEMA-1 (IP-30):

18 Ga. Galvanized Steel

Steel NEMA-4 (IP-65):

18 Ga. Cold Rolled Steel, Powder coated

Warranty:

Five Years (Lifetime on Moisture Migration)

EMC Conformance:

EN 55022, 55024, 61000-3-3, 61000-4-2, 61000-4-3, 61000-4-4, 61000-4-5, 61000-4-6 & 61000-4-11

U.S. PATENT NO. 6592254, 7465087

ORDERING INFORMATION: TE-705-

INSTALLATION	TEMP SENSOR	PROBE LENGTH	PROBE TYPE
B Galvanized Steel Enclosure (NEMA-1 / IP-30)	1 100-Ohm Platinum RTD	A 6 ft (1.8 m)	1 Bendable 3/8" Aluminum
	2 1,000-Ohm Nickel RTD (5,000 PPM)	B 12 ft (3.6 m)	
C Painted Steel Enclosure (NEMA-4 / IP-65)	3 1,000-Ohm Platinum RTD	C 24 ft (7.2 m)	
	4 1,000-Ohm Nickel RTD (6,000 PPM)		
	5 1,000-Ohm Balco RTD		
	7 10,000-Ohm NTC Thermistor (Type III)		
	8 10,000-Ohm NTC Thermistor (Carel)		
	10 3,000-Ohm NTC Thermistor		
	12 10,000-Ohm NTC Thermistor (Type II)		
	13 5,000-Ohm NTC Thermistor		
	14 1,035-Ohm Silicon PTC		
	15 100,000-Ohm NTC Thermistor		
	17 20,000-Ohm NTC Thermistor		
	18 2,252-Ohm NTC Thermistor		
	21 1,800-Ohm NTC Thermistor		

Example: TE-705-B-10-B-1: Duct Averaging Temp Sensor, NEMA-1 enclosure, 12 ft. bendable 3/8" aluminum, 3,000 ohm NTC thermistor.

For **Resistance vs. Temperature** tables, please refer to TI.700-11.

INSTALLATION

Inspection Inspect the package for damage. If damaged, notify the appropriate carrier immediately. If undamaged, open the package and inspect the device for obvious damage. Return damaged products.

- Requirements**
- Tools (*not provided*)
 - Digital Volt-ohm Meter (DVM)
 - Appropriate screwdriver for mounting screws
 - Appropriate drill and drill bit for mounting screws
 - Appropriate accessories
 - Two #8 self-tapping mounting screws (*not provided*)
 - Training: *Installer must be a qualified, experienced technician.*

DUCT AVERAGING TEMPERATURE SENSORS

Mounting

Location: Install the sensor in a location where it will sample the average duct air temperature. Avoid areas where the air is stratified because these areas can cause sensing errors.

TE-705: Refer to **Figure 2** for mounting dimensions.

1. Drill a 7/16-inch (11 mm) hole into the duct where the sensor will be installed.
2. Gently uncoil the sensor's rigid probe and insert it into the duct.
3. Use the flange as a template to mark and drill two holes for the #8 self-tapping sheet metal screws (not provided).
4. Fasten the sensor to the duct with the sheet metal screws. Refer to **Figure 1**.

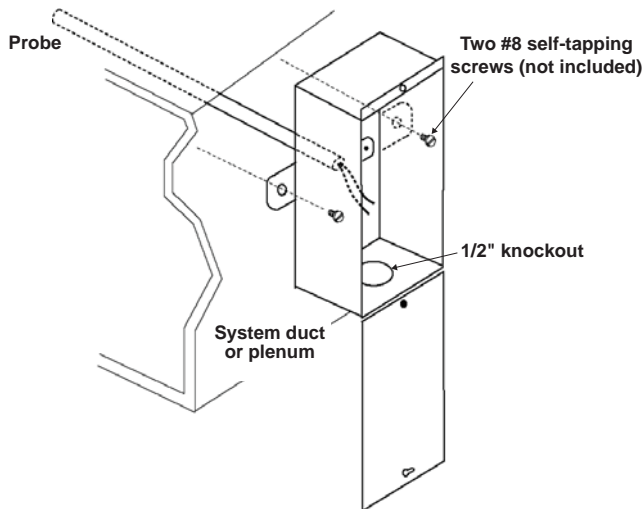

Figure 1 - Installing the TE-705 Sensor

CHECKOUT

Allow the sensor to stabilize in the duct air stream for a minimum of five minutes before taking a resistance measurement.

1. Disconnect the sensor lead wires from the controller.
2. Connect an ohmmeter across the lead wires.
3. Ensure that nominal resistance measurements are in accordance with the resistance/temperature curves. (Refer to **Tables 1 & 2**. For complete **Resistance vs. Temperature** tables, please refer to **TI.700-11** - Temperature Sensor section.)
4. Reconnect sensor lead wires to the controller.
5. Check operation of the complete control system.

MAINTENANCE Regular maintenance of the total system is recommended to assure sustained optimum performance.

FIELD REPAIR None. Replace with a functional unit.

DIMENSIONAL DATA

Figure 2 - TE-705 Duct Averaging Temperature Sensor dimensions shown in inches and millimeters (mm).

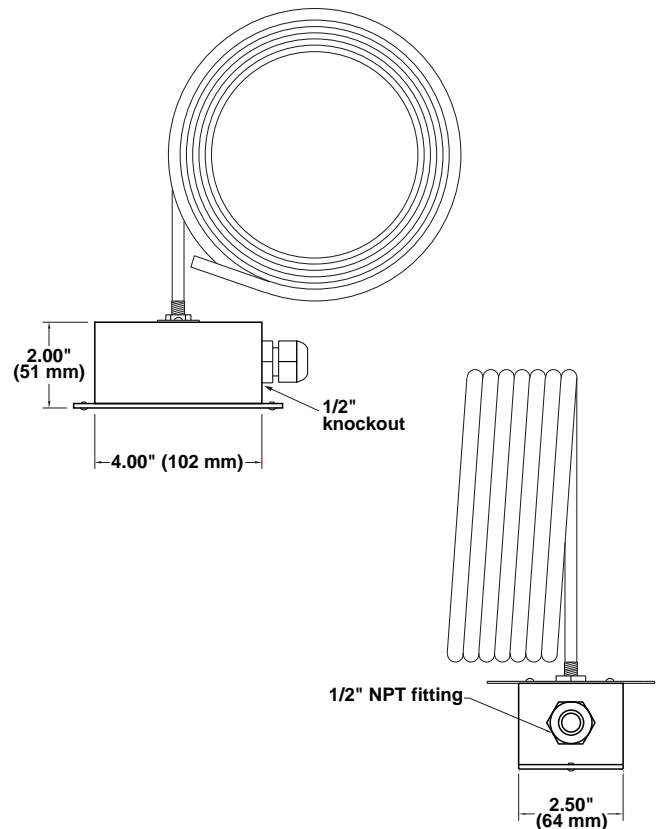

For Technical / Application Assistance call your nearest office



8189 Century Boulevard • Minneapolis, MN 55317-8002 • USA
800-843-5116 • 952-556-4900 • Fax 952-556-4997
sales@mamacsys.com • www.mamacsys.com

EUROPE
Baird House, Units 6 & 7 Dudley Innovation Centre Pensnett Estate • Kingswinford West Midlands • DY6 8XZ United Kingdom 01384-271113 • Fax 01384-271114

AUSTRALIA
4 Arming Court, Unit 2 Holden Hill • S.A. 5088 Australia 08-8395-4333 • Fax 08-8395-4433

ASIA
No. 22 Lorong 21A Geylang #11-02 Prosper Industrial Building Singapore • 388421 656-3927273 • Fax 656-3927276

CANADA
155 McIntosh Drive, Unit 5 Markham • Ontario • L3R 0N6 Canada 905-474-9215 • Fax 905-474-0876

MAMAC Systems, Inc., reserves the right to change any specifications without notice to improve performance, reliability, or function of our products.