

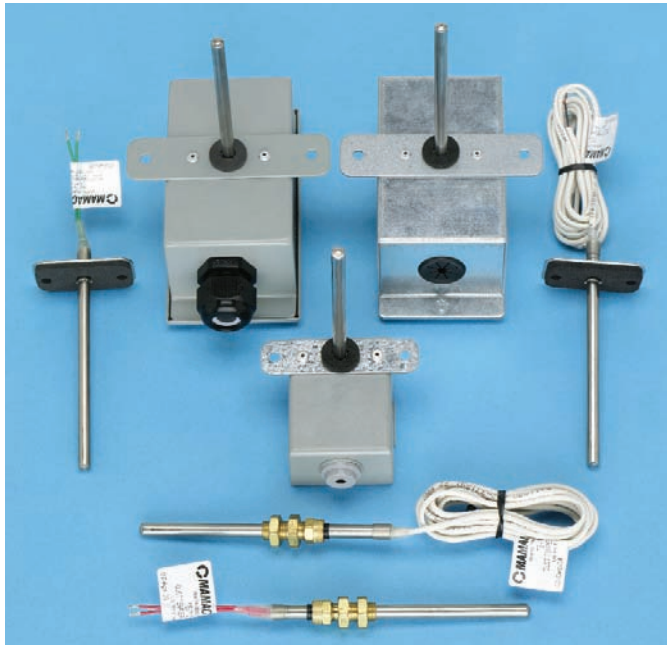

Duct Temperature Sensors

Model TE-701 / 702



- **Five installation options**—probe with mounting flange or bulkhead fitting, plastic, galvanized steel, or NEMA-4 / IP-65 steel enclosure offer the industry's most extensive range to satisfy all HVAC, appliance and industrial applications.
- **304 SS thin wall probe with a cold rolled hermitically sealed end forms a monolithic encapsulation cavity for the sensor and is immune to failures caused by high humidity, contamination, thermal shock and vibration.**
- **The flat probe end provides a large thermally sensitive area and the sensor is in direct thermal contact to this surface. As a result, extremely fast response is achieved to changes in temperature.**
- **Probe is attached to the enclosure or the flange using a patented process to provide a rugged, reliable and low profile attachment for ease of installation.**
- **More than 15 types of interchangeable NTC thermistors, precision platinum, nickel or balco RTD's are available for universal compatibility.**

TE-701/702 temperature sensors offer the industry's most extensive range of enclosure, installation and sensor types to satisfy all HVAC, industrial and commercial applications. These revolutionary sensors incorporate more than twenty five years of product development and experience drawn from millions of installations world wide in all types of applications. This product and process design combined with automated manufacturing processes yields a rugged, reliable, repeatable and stable temperature sensor at a low cost. The only line of temperature sensors offering lifetime warranty against moisture migration related failures.

For large volume OEM customers, TE-701/702 temperature sensors are available in many custom configurations. Wire type, length or gage, terminals, connectors, probe lengths, enclosure options or sensor types may be customized based on volume.



7400 Flying Cloud Drive • Minneapolis, MN 55344-3720 • USA

800-843-5116 • 952-835-1626 • Fax 952-829-5331

sales@mamacsys.com • www.mamacsys.com

Baird House, Units 6&7
Pensnett Estate • Kingswinford
West Midlands • DY6 7YA • United Kingdom
01384-271113 • Fax 01384-271114

4 Armiger Court, Unit 2
Holden Hill • S.A. 5088 • Australia
08-8395-4333 • Fax 08-8395-4433

155 McIntosh Drive, Units 5&6 • Markham
Ontario • L3R 0N6 • Canada
905-474-9215 • Fax 905-474-0876

No. 22 Lorong 21A Geylang #11-02
Chin Hin Hang Building
Singapore • 388421
656-3927273 • Fax 656-3927276

TE-701 / 702

TE-701-A/B Temperature Sensor Flange Mount

Incorporate a hermitically sealed 304 SS probe, crimped on to a Steel flange providing a rugged assembly for duct temperature sensing. Two mounting holes are provided for #8 screws and the flange mating surface is fully gasketted to seal off the probe and screw holes. TE-701-A is available with 3 in/75mm wire leads and the TE-701-B has 6 ft/1.8 meter plenum rated cable. TE-701-A/B is an ideal product for a rugged, reliable, quick and easy installation in air handlers, fan coil units, ducts, furnaces, freezers, ovens or any other through the wall temperature sensing application.



TE-701-C/D Temperature Sensor Bulkhead Mount

Fast response 304 SS probe with a brass bulkhead fitting and a compression sleeve forms a strong assembly for duct temperature sensing if adjustable insertion depth is desired. The bulkhead fitting is installed in the duct, compression sleeve loosened, probe inserted to the desired length and the sleeve is tightened. Sensor is available with 3 in/75mm leads or 6 ft/1.8 meter plenum rated cable. TE-701-C/D sensors provide a low cost, rugged, quick and easy installation in air handlers, fan coil units, ducts, plenum, furnaces, freezers, ovens or any other through the wall temperature sensing application which requires adjustable insertion length.



TE-702-A Temperature Sensor Polycarb Enclosure

Corrosion free 30% glass filled polycarbonate enclosure designed to withstand temperature extremes, mechanical shock and vibration. 304 SS probe crimp attached to the enclosure flange for a low profile mating surface, external mounting bracket to conform to irregular surfaces, single screw cover attachment, are some of the features which improve reliability and lower installation cost. TE-702-A temperature sensors provide a cost effective and reliable solution for air handlers, fan coil units, ducts, plenums, furnaces or any other application which does not require conduit wiring.



TE-701/702

TE-702-B Temperature Sensor Galvanized Steel Enclosure

Industry standard NEMA-1 / IP-30 galvanized sheet metal enclosure designed for all industrial and commercial duct temperature sensing applications. Hermitically sealed, fast response 304 SS probe crimp attached to the enclosure flange to provide a low profile mating surface, external mounting bracket to conform to uneven surfaces, keyed enclosure cover to swing open without removing the screws, 1/2" conduit opening, are some of the features which improve reliability and lower installation cost.



TE-702-C Temperature Sensor Powder Coated Steel Enclosure

Rugged steel enclosure with welded seams, gasketed cover and powder coated finish, rated NEMA-4 / IP-65 for harsh environments. TE-702-C has all the other features including a 304 SS probe, external mounting bracket, conduit opening similar to the TE-702-B series except designed for applications in unconditioned environments where the unit maybe subjected to dirt, condensation, oil vapor and other contaminants.

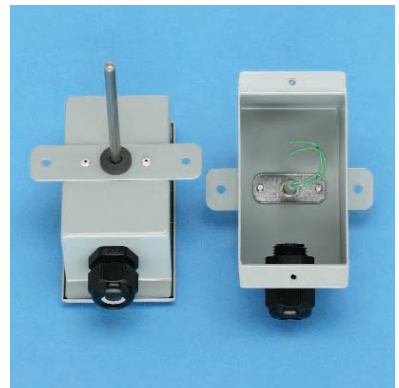

SPECIFICATIONS:

Platinum RTD sensors:	+/- 0.1% @ 0 C, Alpha : 385 per DIN 43760
Nickel RTD sensors: (#2)	+/- 0.5 C @ 0 C, 5000 PPM/K T.C.R.
Nickel RTD sensors: (#4)	+/- 0.5 F @ 70 F / 21.1 C, 6000 PPM/K T.C.R.
Balco RTD sensors:	+/- 0.5 F @ 70 F / 21.1 C, 4300 PPM/K T.C.R.
Thermistor sensors:	+/- 0.2 C interchangeability @ 77 F/ 0 C
Probe Material:	1/4" / 6.3mm O.D, 0.020" / 0.5mm wall 304 Stainless Steel
Flange Material:	Galvanized Steel
Bulkhead Fitting:	Brass with poly compression sleeve
Plastic Enclosure:	Polycarbonate 30% glass filled, rated UL 94V-5-0
Steel NEMA-1 / IP-30:	18 Ga. Galvanized Steel
Steel NEMA-4 / IP-65:	18 Ga. Cold Rolled Steel, Powder coated
Operating Temp:	-40F/-40C to 210F/100C
Ambient Temp:	-40F/-40C to 160F/70C
Warranty:	Five Years (Lifetime on Moisture Migration).

U.S. PATENT NO. 6457857, 6555748, 7036224

TE-701-A/B

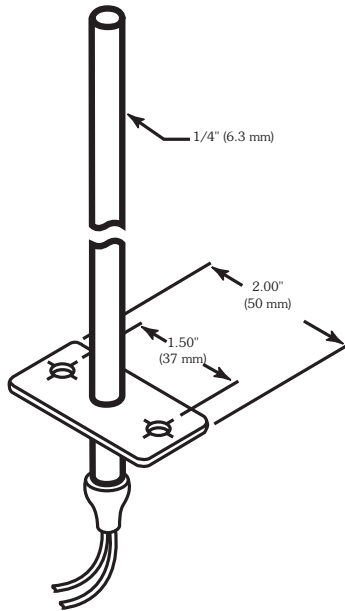

TE-701-C/D

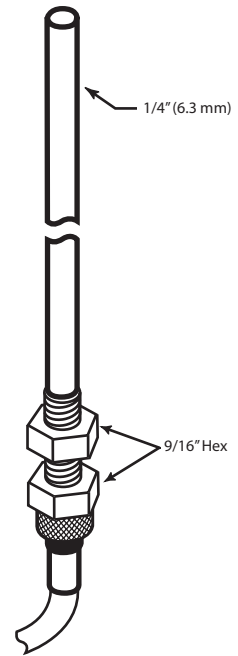

TE-702-A

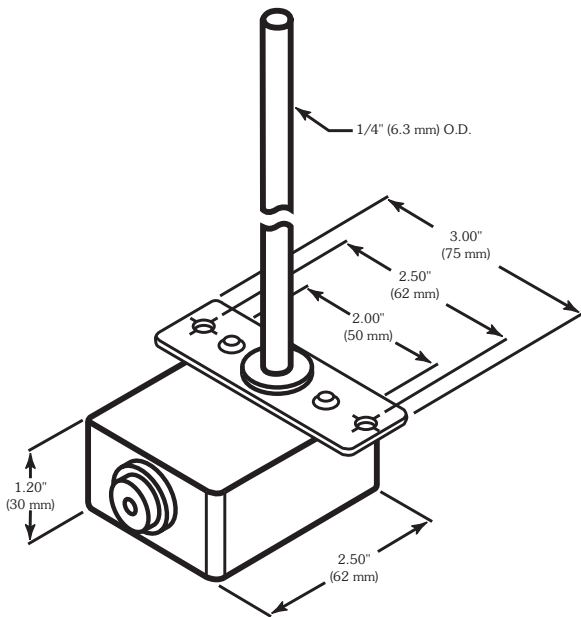

TE-702-B/C

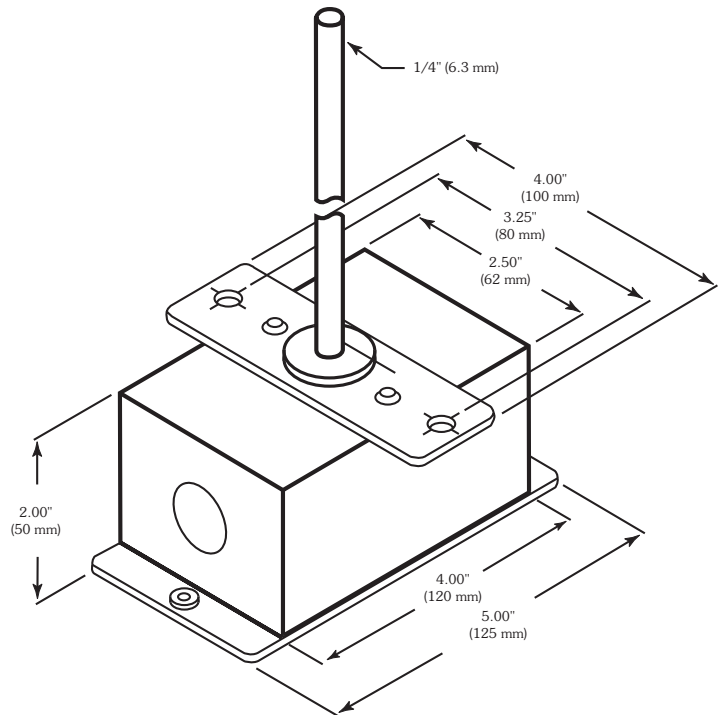

ORDERING INFORMATION: TE-701

Installation	Sensor*	Probe Length
A Flange mount 3 in/175mm wire leads	1 100 ohm Platinum RTD 2 1,000 ohm Nickel RTD (5000 PPM)	A 4 inches/100mm B 6 inches/150mm
B Flange mount 6 ft/1.8m plenum cable	3 1,000 ohm Platinum RTD 4 1,000 ohm Nickel RTD (6000 PPM)	C 8 inches/200mm D 12 inches/300mm
C Bulkhead mount 3 in/175mm wire leads	5 1,000 ohm Balco RTD 7 10,000 ohm NTC thermistor (Type III)	
D Bulkhead mount 6 ft/1.8m plenum cable	8 10,000 ohm NTC thermistor (Carel) 10 3,000 ohm NTC thermistor 12 10,000 ohm NTC thermistor (Type II)	
	13 5,000 ohm NTC thermistor 14 1,035 ohm Silicon PTC	
	15 100,000 ohm NTC thermistor 17 20,000 ohm NTC thermistor	
	18 2,252 ohm NTC thermistor 21 1,800 ohm NTC thermistor	

Example: TE-701-B-10-A: Flange mount with 6 ft cable, 3000 ohm thermistor and 4 inch probe length.

ORDERING INFORMATION: TE-702

Installation	Sensor*	Probe Length
A Polycarb Plastic Enclosure IP-54	1 100 ohm Platinum RTD 2 1,000 ohm Nickel RTD (5000 PPM)	A 4 inches/100mm B 6 inches/150mm
B Galvanized Steel Enclosure NEMA-1 / IP-30	3 1,000 ohm Platinum RTD 4 1,000 ohm Nickel RTD (6000 PPM)	C 8 inches/200mm D 12 inches/300mm
C Painted Steel Enclosure NEMA-4 / IP-65	5 1,000 ohm Balco RTD 7 10,000 ohm NTC thermistor (Type III)	
	8 10,000 ohm NTC thermistor (Carel) 10 3,000 ohm NTC thermistor 12 10,000 ohm NTC thermistor (Type II)	
	13 5,000 ohm NTC thermistor 14 1,035 ohm Silicon PTC	
	15 100,000 ohm NTC thermistor 17 20,000 ohm NTC thermistor	
	18 2,252 ohm NTC thermistor 21 1,800 ohm NTC thermistor	

Example: TE-702-A-3-D: Polycarb plastic enclosure with 1000 ohm Platinum RTD and 12 inch probe length.

* For sensor compatibility, please refer to TI.700-10.

** For a complete Resistance vs. Temperature tables, please refer to TI.700-11.



7400 Flying Cloud Drive • Minneapolis, MN 55344-3720 • USA

800-843-5116 • 952-835-1626 • Fax 952-829-5331

sales@mamacsys.com • www.mamacsys.com

*Baird House, Units 6&7
Pensnett Estate • Kingswinford
West Midlands • DY6 7YA • United Kingdom
01384-271113 • Fax 01384-271114*

*4 Armiger Court, Unit 2
Holden Hill • S.A. 5088 • Australia
08-8395-4333 • Fax 08-8395-4433*

*155 McIntosh Drive, Units 5&6 • Markham
Ontario • L3R 0N6 • Canada
905-474-9215 • Fax 905-474-0876*

*No. 22 Lorong 21A Geylang #11-02
Chin Hin Hang Building
Singapore • 388421
656-3927273 • Fax 656-3927276*