



8189 Century Boulevard • Minneapolis, MN 55317-8002 • USA
 800-843-5116 • 952-556-4900 • Fax 952-556-4997
 sales@mamacsys.com • www.mamacsys.com



Model TE-701/702
Technical Information
TI.701/702-02

DUCT TEMPERATURE SENSORS

For Additional Information See TE-701/702 Data Sheet

SPECIFICATIONS

Platinum RTD Sensors:

±0.1% @ 32°F (0°C), Alpha: 385 per DIN 43760

Nickel RTD Sensors (#2):

±0.5°C @ 0°C (32°F), 5,000 PPM/K T.C.R.

Nickel RTD Sensors (#4):

±0.5°F @ 70°F (21.1°C), 6,000 PPM/K T.C.R.

Balco RTD Sensors:

±0.5°F @ 70°F (21.1°C), 4,300 PPM/K T.C.R.

Thermistor Sensors:

±0.2°C interchangeability @ 77°F (25°C)

Operating Temperature:

-40°F to 210°F (-40°C to 100°C)

Ambient Temperature:

-40°F to 160°F (-40°C to 70°C)

Probe Material:

1/4" (6.3 mm) O.D., 0.020" (0.5 mm) wall, 304 Stainless Steel

Flange Material:

Galvanized Steel

Bulkhead Fitting:

Brass with poly compression sleeve

Plastic Enclosure:

Polycarbonate 30% glass filled, rated UL 94V-5-0

Steel NEMA-1 (IP-30):

18 Ga. Galvanized Steel

Steel NEMA-4 (IP-65):

18 Ga. Cold Rolled Steel, Powder coated

Warranty:

Five Years (Lifetime on Moisture Migration)

EMC Conformance:

EN 55022, 55024, 61000-3-3, 61000-4-2, 61000-4-3, 61000-4-4, 61000-4-5, 61000-4-6 & 61000-4-11

U.S. PATENT NO. 6457857, 6555748, 7036224

ORDERING INFORMATION: TE-701-

INSTALLATION	TEMP SENSOR	PROBE LENGTH
A Flange mount 3" (175 mm) wire leads	1 100-Ohm Platinum RTD	A 4" (100 mm)
	2 1,000-Ohm Nickel RTD (5,000 PPM)	B 6" (150 mm)
B Flange mount 6" (1.8 m) plenum cable	3 1,000-Ohm Platinum RTD	C 8" (200 mm)
	4 1,000-Ohm Nickel RTD (6,000 PPM)	D 12" (300 mm)
C Bulkhead mount 3" (175 mm) wire leads	5 1,000-Ohm Balco RTD	
	7 10,000-Ohm NTC Thermistor (Type III)	
D Bulkhead mount 6" (1.8 m) plenum cable	8 10,000-Ohm NTC Thermistor (Carel)	
	10 3,000-Ohm NTC Thermistor	
	12 10,000-Ohm NTC Thermistor (Type II)	
	13 5,000-Ohm NTC Thermistor	
	14 1,035-Ohm Silicon PTC	
	15 100,000-Ohm NTC Thermistor	
	17 20,000-Ohm NTC Thermistor	
	18 2,252-Ohm NTC Thermistor	
	21 1,800-Ohm NTC Thermistor	

Example: TE-701-B-10-A: Flange mount with 6' cable, 3K ohm thermistor and 4" probe.

ORDERING INFORMATION: TE-702-

INSTALLATION	TEMP SENSOR	PROBE LENGTH
A Polycarb Plastic Enclosure (IP-54)	1 100-Ohm Platinum RTD	A 4" (100 mm)
	2 1,000-Ohm Nickel RTD (5,000 PPM)	B 6" (150 mm)
B Galvanized Steel Enclosure (NEMA-1 / IP-30)	3 1,000-Ohm Platinum RTD	C 8" (200 mm)
	4 1,000-Ohm Nickel RTD (6,000 PPM)	D 12" (300 mm)
C Painted Steel Enclosure (NEMA-4 / IP-65)	5 1,000-Ohm Balco RTD	
	7 10,000-Ohm NTC Thermistor (Type III)	
	8 10,000-Ohm NTC Thermistor (Carel)	
	10 3,000-Ohm NTC Thermistor	
	12 10,000-Ohm NTC Thermistor (Type II)	
	13 5,000-Ohm NTC Thermistor	
	14 1,035-Ohm Silicon PTC	
	15 100,000-Ohm NTC Thermistor	
	17 20,000-Ohm NTC Thermistor	
	18 2,252-Ohm NTC Thermistor	
	21 1,800-Ohm NTC Thermistor	

Example: TE-702-A-3-D: Polycarb plastic enclosure with 1K ohm Platinum RTD and 4" probe.

DUCT TEMPERATURE SENSORS

INSTALLATION

Inspection Inspect the package for damage. If damaged, notify the appropriate carrier immediately. If undamaged, open the package and inspect the device for obvious damage. Return damaged products.

Requirements

- Tools (*not provided*)
 - Digital Volt-ohm Meter (DVM)
 - Appropriate screwdriver for mounting screws
 - Appropriate drill and drill bit for mounting screws
- Appropriate accessories
- Two #8 self-tapping mounting screws (*not provided*)
- Training: *Installer must be a qualified, experienced technician.*

Warning:

- Do not use on oxygen service, in an explosive/hazardous environment, or with flammable/combustible media.
- Disconnect power supply before installation to prevent electrical shock and equipment damage.
- Make all connections in accordance with the job wiring diagram and in accordance with national and local electrical codes. Use copper conductors only.



Caution:

- Use electrostatic discharge precautions (e.g., use of wrist straps) during installation and wiring to prevent equipment damage.
- Avoid locations where severe shock or vibration, excessive moisture or corrosive fumes are present. NEMA-4 housings are intended for outdoor use primarily to provide a degree of protection against wind-blown dust, rain, and hose-directed water.
- Do not exceed ratings of the device.



Mounting

Location: *Install the sensor in a location where it will sample the average air temperature in a duct. Avoid areas where the air is stratified because these areas can cause sensing errors.*

TE-701-A or B: Refer to **Figure 4** for mounting dimensions.

1. Drill a 3/8-inch (9 mm) hole into the duct or plenum where the sensor will be installed.
2. Insert the sensor probe into the duct or plenum until the flange rests against the duct or plenum wall.
3. Use the flange as a template to mark and drill holes for two #8 self-tapping sheet metal screws (*not provided*).
4. Fasten the sensor to the duct or plenum wall with the sheet metal screws.
5. Make the wiring connections. Refer to **Figure 1**.

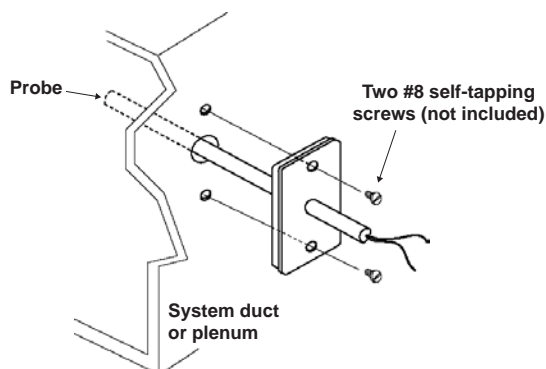

Figure 1 - Installing the TE-701-A or TE-701-B Sensor

TE-701-C or D: Refer to **Figure 5** for mounting dimensions.

1. Drill a 3/8-inch (9 mm) hole into the duct or plenum where the sensor will be installed.
2. Remove the mounting nut from the bulkhead fitting.
3. Insert the sensor probe into the duct or plenum until the bulkhead fitting rests against the duct or plenum wall.
4. Guide the nut along the probe and tighten against the duct or plenum.
5. Make the wiring connections. Refer to **Figure 2**.

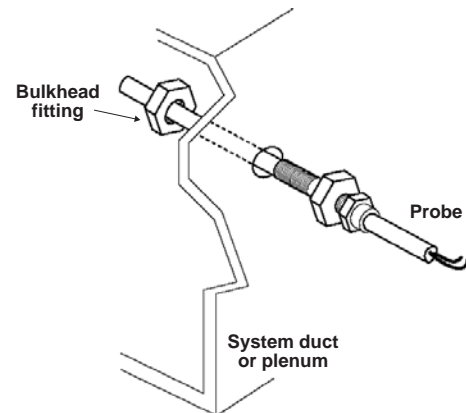

Figure 2 - Installing the TE-701-C or TE-701-D Sensor

TE-702-A, B, or C: Refer to **Figures 6 & 7** for mounting dimensions.

1. Drill a 3/8-inch (9 mm) hole into the duct or plenum where the sensor will be installed.
2. Insert the sensor probe into the duct or plenum until the mounting bracket rests against the duct or plenum wall.
3. Use the mounting bracket as a template to mark and drill holes for two #8 self-tapping sheet metal screws (*not provided*).
4. Fasten the sensor to the duct or plenum wall with the sheet metal screws.
5. Loosen the cover screws and rotate the cover out of the way.
6. Make the wiring connections. Rotate and screw the cover back into place. Refer to **Figure 3**.

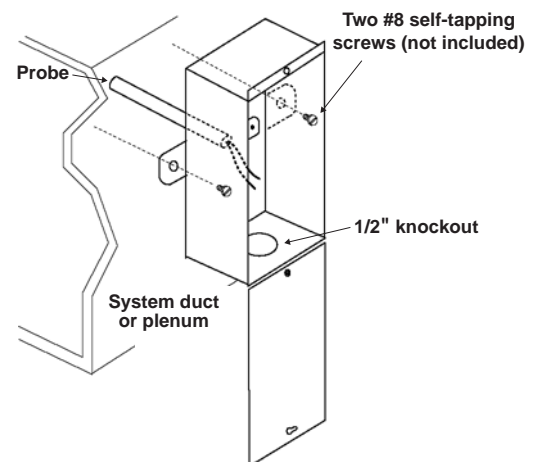

Figure 3 - Installing the TE-702-A, TE-702-B, or TE-702-C Sensor

DUCT TEMPERATURE SENSORS

CHECKOUT

Allow the sensor to stabilize in the duct air stream for a minimum of five minutes before taking a resistance measurement.

1. Disconnect the sensor lead wires from the controller.
2. Connect an ohmmeter across the lead wires.
3. Ensure that nominal resistance measurements are in accordance with the resistance/temperature curves. (Refer to **Tables 1 & 2**. For complete **Resistance vs. Temperature** tables, please refer to **TI.700-11** - Temperature Sensor section.)
4. Reconnect sensor lead wires to the controller.
5. Check operation of the complete control system.

MAINTENANCE Regular maintenance of the total system is recommended to assure sustained optimum performance.

FIELD REPAIR None. Replace with a functional unit.

DIMENSIONAL DATA

TE-701/702 Duct Temperature Sensor dimensions shown in inches and millimeters (mm).

Figure 4
TE-701-A & TE-701-B

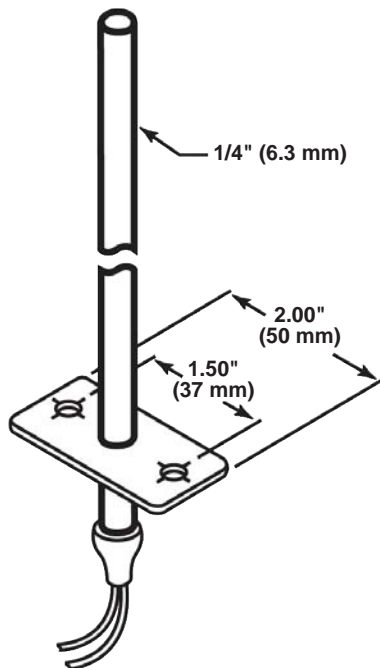

Figure 5
TE-701-C & TE-701-D

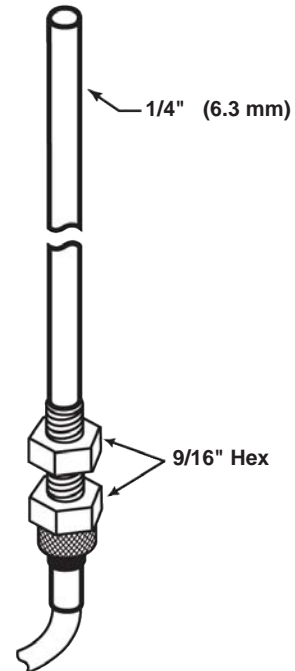
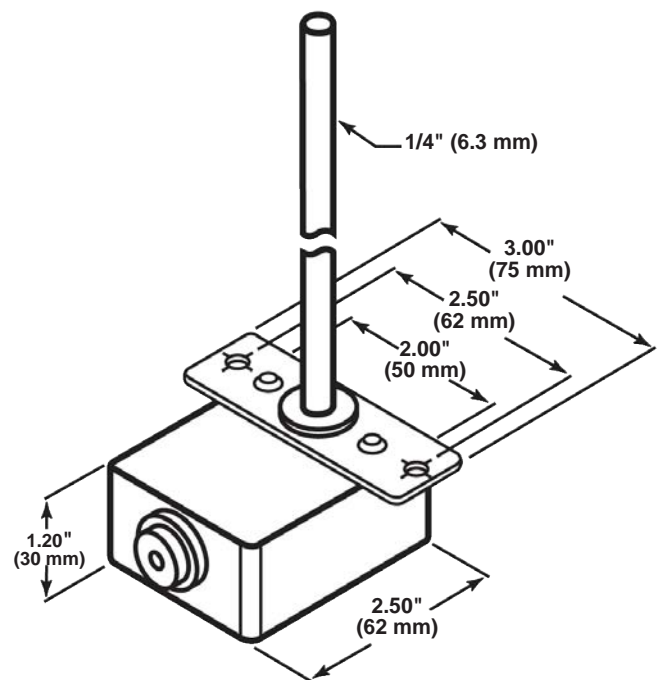

Figure 6
TE-702-A





DUCT TEMPERATURE SENSORS

Figure 7
 TE-702-B & TE-702-C

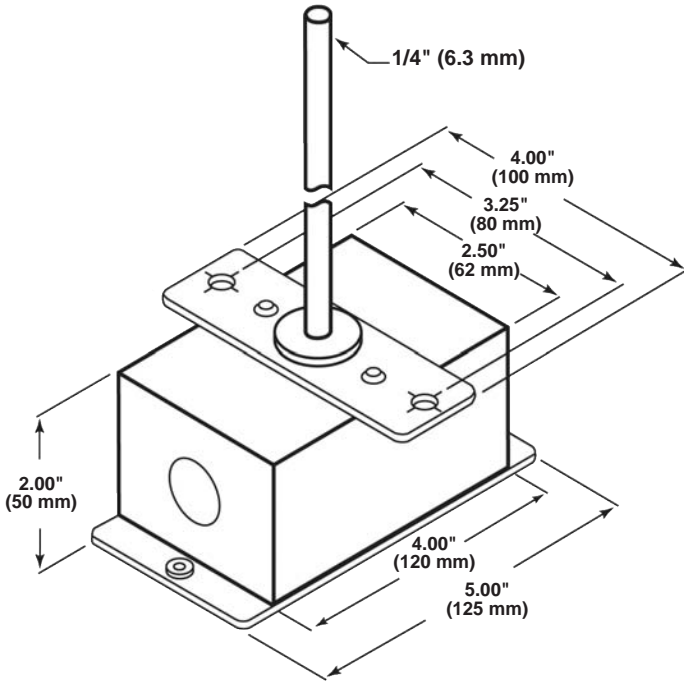

Table 1. Resistance Versus Temperature

*F	°C	Type 1 RTD	Type 3 RTD	Type 4 RTD	Type 5 RTD	Type 7 thermistor	Type 10 thermistor
72	22.2	108.66	1,086.6	1,006.0	1,004.4	11,194	3,392
72.5	22.5	108.76	1,087.6	1,007.5	1,005.5	11,068	3,350
73	22.8	108.87	1,088.7	1,009.0	1,006.6	10,943	3,309
73.5	23	108.98	1,089.8	1,010.5	1,007.6	10,820	3,269
74	23.3	109.09	1,090.9	1,012.0	1,008.7	10,698	3,229
74.5	23.6	109.19	1,091.9	1,013.5	1,009.8	10,578	3,189
75	23.9	109.30	1,093.0	1,015.1	1,011.0	10,459	3,150
75.5	24.1	109.41	1,094.1	1,016.6	1,012.1	10,343	3,112
76	24.4	109.52	1,095.2	1,018.1	1,013.2	10,227	3,074
76.5	24.7	109.62	1,096.2	1,019.6	1,014.3	10,113	3,037
77	25	109.73	1,097.3	1,021.1	1,015.4	10,000	3,000
77.5	25.3	109.84	1,098.4	1,022.6	1,016.5	9,889	2,964
78	25.5	109.95	1,099.5	1,024.1	1,017.6	9,779	2,928
78.5	25.8	110.06	1,100.1	1,025.6	1,018.7	9,671	2,890
79	26.1	110.17	1,101.7	1,027.2	1,019.8	9,563	2,858
79.5	26.4	110.27	1,102.7	1,028.7	1,020.9	9,458	2,823
80	26.7	110.38	1,103.8	1,030.2	1,022.1	9,353	2,789
80.5	27	110.49	1,104.9	1,031.7	1,023.2	9,250	2,756
81	27.2	110.60	1,106.0	1,033.3	1,024.3	9,148	2,723
81.5	27.5	110.70	1,107.0	1,034.8	1,025.4	9,045	2,690
82	27.8	110.81	1,108.1	1,036.3	1,026.5	8,943	2,658

Table 2. Resistance Versus Temperature

*F	°C	Type 12 thermistor	Type 13 thermistor	Type 15 thermistor	Type 17 thermistor	Type 18 thermistor	Type 21 thermistor
72	22.2	11,307	5,654	113,080	22,825	2,546	2,005
72.5	22.5	11,169	5,584	111,680	22,525	2,515	1,983
73	22.8	11,031	5,515	110,300	22,226	2,484	1,962
73.5	23	10,896	5,448	108,960	21,935	2,454	1,941
74	23.3	10,762	5,381	107,620	21,645	2,424	1,920
74.5	23.6	10,631	5,316	106,320	21,362	2,394	1,899
75	23.9	10,501	5,251	105,020	21,080	2,365	1,879
75.5	24.1	10,374	5,188	103,760	20,806	2,336	1,859
76	24.4	10,247	5,124	102,480	20,532	2,308	1,839
76.5	24.7	10,123	5,062	101,240	20,266	2,280	1,819
77	25	10,000	5,000	100,000	20,000	2,252	1,800
77.5	25.3	9,880	4,940	98,800	19,741	2,225	1,791
78	25.5	9,760	4,880	97,600	19,483	2,198	1,762
78.5	25.8	9,643	4,821	96,420	19,232	2,171	1,743
79	26.1	9,526	4,763	95,260	18,981	2,145	1,725
79.5	26.4	9,412	4,706	94,120	18,737	2,119	1,707
80	26.7	9,298	4,649	92,980	18,494	2,094	1,689
80.5	27	9,187	4,616	92,320	18,257	2,069	1,671
81	27.2	9,077	4,583	91,660	18,020	2,044	1,653
81.5	27.5	8,969	4,507	90,140	17,790	2,020	1,636
82	27.8	8,861	4,431	88,620	17,560	1,996	1,619

For complete *Resistance Versus Temperature* tables, please refer to TI.700-11.

For Technical / Application Assistance call your nearest office



8189 Century Boulevard • Minneapolis, MN 55317-8002 • USA
800-843-5116 • 952-556-4900 • Fax 952-556-4997
sales@mamacsys.com • www.mamacsys.com

<p>EUROPE 4200 Waterside Centre Solihull Parkway Birmingham • West Midlands B37 7YN • United Kingdom 01384-271113 • Fax 01384-271114</p>	<p>CANADA 675 Cochrane Drive East Tower • 6th Floor Toronto • Ontario L3R 0B8 • Canada 905-474-9215 • Fax 905-474-0876</p>
--	--

<p>ASIA 1 Fullerton Road #02-01 One Fullerton Singapore • 049213 65-31581826 • Fax 65-31581826</p>	<p>AUSTRALIA 4 Armiger Court, Unit 2 Adelaide • S.A. 5088 • Australia 08-8395-4333 • Fax 08-8395-4433</p>
---	--

MAMAC Systems, Inc., reserves the right to change any specifications without notice to improve performance, reliability, or function of our products.