



8189 Century Boulevard • Minneapolis, MN 55317-8002 • USA
 800-843-5116 • 952-556-4900 • Fax 952-556-4997
 sales@mamacsys.com • www.mamacsys.com



Model TE-703/704
Technical Information
 TI.703/704-02

PIPE TEMPERATURE SENSORS

For Additional Information See TE-703/704 Data Sheet

SPECIFICATIONS

Platinum RTD Sensors:
 ±0.1% @ 32°F (0°C), Alpha: 385 per DIN 43760

Nickel RTD Sensors (#2):
 ±0.5°C @ 0°C (32°F), 5,000 PPM/K T.C.R.

Nickel RTD Sensors (#4):
 ±0.5°F @ 70°F (21.1°C), 6,000 PPM/K T.C.R.

Balco RTD Sensors:
 ±0.5°F @ 70°F (21.1°C), 4,300 PPM/K T.C.R.

Thermistor Sensors:
 ±0.2°C interchangeability @ 77°F (25°C)

Operating Temperature:
 -40°F to 210°F (-40°C to 100°C)

Ambient Temperature:
 -40°F to 160°F (-40°C to 70°C)

Probe Material:
 1/4" (6.3mm) O.D., 0.020" (0.5mm) wall, 304 Stainless Steel

Flange Material:
 Galvanized Steel

Bulkhead Fitting:
 Brass with poly compression sleeve

Plastic Enclosure:
 Polycarbonate 30% glass filled, rated UL 94V-5-0

Steel NEMA-1 (IP-30):
 18 Ga. Galvanized Steel

Steel NEMA-4 (IP-65):
 18 Ga. Cold Rolled Steel, Powder coated

Warranty:
 Five Years (Lifetime on Moisture Migration)

EMC Conformance:
 EN 55022, 55024, 61000-3-3, 61000-4-2, 61000-4-3,
 61000-4-4, 61000-4-5, 61000-4-6 & 61000-4-11
 U.S. PATENT NO. 6457857, 6555748, 6599012, 7036224

ORDERING INFORMATION: TE-703-

INSTALLATION	TEMP SENSOR	PROBE LENGTH	ADAPTER
A Immersion style with adapter	1 100-Ohm Platinum RTD	A 4" (100 mm)	1 1/8" NPT
B Polycarb Plastic Enclosure (IP-54)	2 1,000-Ohm Nickel RTD (5,000 PPM)	B 6" (150 mm)	2 1/4" NPT
		C 8" (200 mm)	3 1/2" NPT
C Galvanized Steel Enclosure (NEMA-1 / IP-30)	3 1,000-Ohm Platinum RTD		
	4 1,000-Ohm Nickel RTD (6,000 PPM)		
D Painted Steel Enclosure (NEMA-4 / IP-65)	5 1,000-Ohm Balco RTD		
	7 10,000-Ohm NTC Thermistor (Type III)		
	8 10,000-Ohm NTC Thermistor (Carel)		
	10 3,000-Ohm NTC Thermistor		
	12 10,000-Ohm NTC Thermistor (Type II)		
	13 5,000-Ohm NTC Thermistor		
	14 1,035-Ohm Silicon PTC		
	15 100,000-Ohm NTC Thermistor		
	17 20,000-Ohm NTC Thermistor		
	18 2,252-Ohm NTC Thermistor		
	21 1,800-Ohm NTC Thermistor		

Examples:

TE-703-A-10-A-3: Immersion style with 1/2" adapter, 3,000 ohm thermistor & 4" probe.
TE-703-D-10-C-2: NEMA-4 enclosure, 3,000 ohm thermistor, 8" probe & 1/4" NPT brass fitting.

ORDERING INFORMATION: TE-704-

INSTALLATION	TEMP SENSOR
A Surface Mount Strap-On	1 100-Ohm Platinum RTD
B Polycarb Plastic Enclosure (IP-54)	2 1,000-Ohm Nickel RTD (5,000 PPM)
	3 1,000-Ohm Platinum RTD
C Galvanized Steel Enclosure (NEMA-1 / IP-30)	4 1,000-Ohm Nickel RTD (6,000 PPM)
	5 1,000-Ohm Balco RTD
D Painted Steel Enclosure (NEMA-4 / IP-65)	7 10,000-Ohm NTC Thermistor (Type III)
	8 10,000-Ohm NTC Thermistor (Carel)
	10 3,000-Ohm NTC Thermistor
	12 10,000-Ohm NTC Thermistor (Type II)
	13 5,000-Ohm NTC Thermistor
	14 1,035-Ohm Silicon PTC
	15 100,000-Ohm NTC Thermistor
	17 20,000-Ohm NTC Thermistor
	18 2,252-Ohm NTC Thermistor
	21 1,800-Ohm NTC Thermistor

Example: TE-704-C-1: NEMA-1 enclosure with 100 ohm Platinum RTD surface mount sensor.

PIPE TEMPERATURE SENSORS

INSTALLATION

Inspection Inspect the package for damage. If damaged, notify the appropriate carrier immediately. If undamaged, open the package and inspect the device for obvious damage. Return damaged products.

Requirements

- Tools (*not provided*)
 - Digital Volt-ohm Meter (DVM)
 - Appropriate screwdriver for mounting screws
 - Appropriate drill and drill bit for mounting screws
- Appropriate accessories
- Two #8 self-tapping mounting screws (*not provided*)
- Training: *Installer must be a qualified, experienced technician.*

Warning:

- Do not use on oxygen service, in an explosive/hazardous environment, or with flammable/combustible media.
- Disconnect power supply before installation to prevent electrical shock and equipment damage.
- Make all connections in accordance with the job wiring diagram and in accordance with national and local electrical codes. Use copper conductors only.



Caution:

- Use electrostatic discharge precautions (e.g., use of wrist straps) during installation and wiring to prevent equipment damage.
- Avoid locations where severe shock or vibration, excessive moisture or corrosive fumes are present. NEMA-4 housings are intended for outdoor use primarily to provide a degree of protection against wind-blown dust, rain, and hose-directed water.
- Do not exceed ratings of the device.



Mounting

Mount the Immersion Sensor: Refer to **Figures 4, 5 & 6** for mounting dimensions.

1. TE-703-A:

- Loosen the compression fitting and remove the probe. Refer to **Figure 1**.
- Screw the adapter into the thermowell.
- Apply A-505 thermal compound to the probe tip and insert the probe until it is seated against the thermowell.
- Tighten the nut.

TE-703-B, C, or D:

- Loosen the set screw. Refer to **Figure 1**.
 - Remove the adapter and thread it into the thermowell. Tighten.
 - Apply A-505 thermal compound to the probe tip and insert the probe until it is seated against the thermowell. Ensure that the set screw is accessible.
 - Lock the adapter into place and tighten the set screw.
 - Loosen the cover screws and rotate the cover out of the way.
- Make the wiring connections.
 - Rotate and screw the cover back into place.

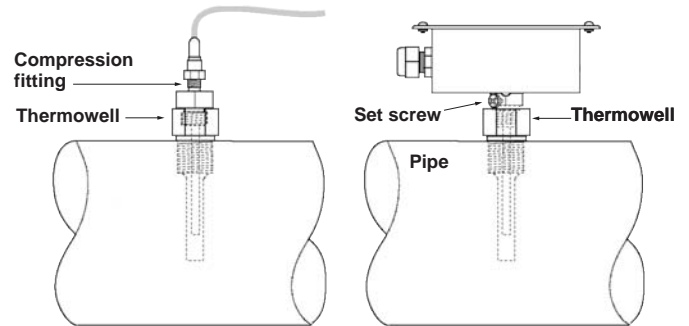

Figure 1 - Installing the Immersion Sensor

TE-704-A:

- Scrape any rust or scale off the pipe surface.
- Apply a thin layer of A-505 thermal compound to the sensor.
- Position the sensor flat against the pipe and fasten with a hose clamp or nylon ties (*not provided*). Refer to **Figure 2**.
- Make the wiring connections. Insulate around the sensor if necessary.

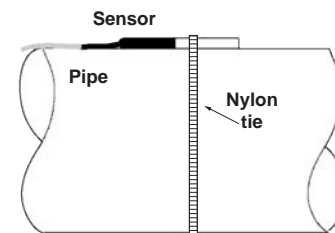

Figure 2 - Installing the TE-704-A Sensor

TE-704-B, C, or D: Refer to **Figures 7 & 8** for mounting dimensions.

- Scrape any rust or scale off the pipe surface.
- Apply a thin layer of A-505 thermal compound to the sensing element. Refer to **Figure 3**.
- Position the sensor's sensing element so that it makes contact with the pipe and fasten with two pipe clamps (*not provided*).
- Loosen the cover screws and rotate the cover out of the way.
- Make the wiring connections. Rotate and screw the cover back into place.

PIPE TEMPERATURE SENSORS

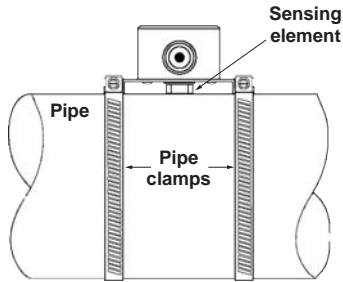

Figure 3 - Installing the TE-704-B, TE-704-C, or TE-704-D Sensor

CHECKOUT

Allow the sensor to stabilize in (or against) the pipe for a minimum of five minutes before taking a resistance measurement.

1. Disconnect the sensor lead wires from the controller.
2. Connect an ohmmeter across the lead wires.
3. Ensure that nominal resistance measurements are in accordance with the resistance/temperature curves. (Refer to **Tables 1 & 2**. For complete **Resistance vs. Temperature** tables, please refer to **TI.700-11** - Temperature Sensor section.)
4. Reconnect sensor lead wires to the controller.
5. Check operation of the complete control system.

MAINTENANCE Regular maintenance of the total system is recommended to assure sustained optimum performance.

FIELD REPAIR None. Replace with a functional unit.

DIMENSIONAL DATA

TE-703/704 Pipe Temperature Sensors dimensions shown in inches and millimeters (mm).

Figure 4
TE-703-A

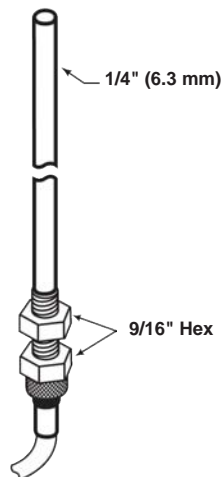

Figure 5
TE-703-B

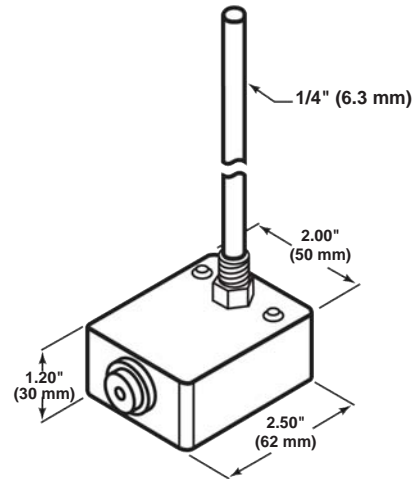

Figure 6
TE-703-C & TE-703-D

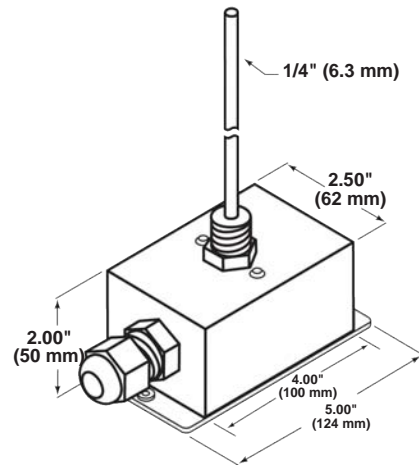
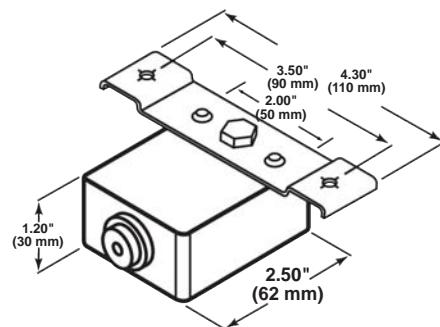

Figure 7
TE-704-B





PIPE TEMPERATURE SENSORS

Figure 8
 TE-704-C & TE-704-D

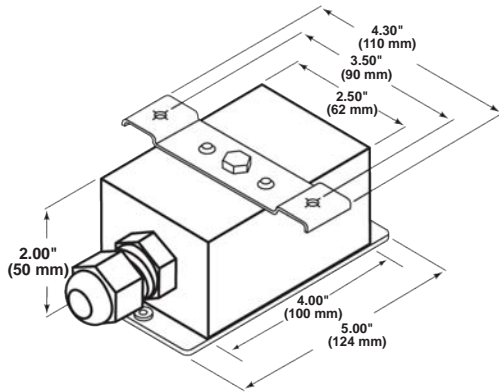

Table 1. Resistance Versus Temperature

°F	°C	Type 1 RTD	Type 3 RTD	Type 4 RTD	Type 5 RTD	Type 7 thermistor	Type 10 thermistor
72	22.2	108.66	1,086.6	1,006.0	1,004.4	11,194	3,392
72.5	22.5	108.76	1,087.6	1,007.5	1,005.5	11,068	3,350
73	22.8	108.87	1,088.7	1,009.0	1,006.6	10,943	3,309
73.5	23	108.98	1,089.8	1,010.5	1,007.6	10,820	3,269
74	23.3	109.09	1,090.9	1,012.0	1,008.7	10,698	3,229
74.5	23.6	109.19	1,091.9	1,013.5	1,009.8	10,578	3,189
75	23.9	109.30	1,093.0	1,015.1	1,011.0	10,459	3,150
75.5	24.1	109.41	1,094.1	1,016.6	1,012.1	10,343	3,112
76	24.4	109.52	1,095.2	1,018.1	1,013.2	10,227	3,074
76.5	24.7	109.62	1,096.2	1,019.6	1,014.3	10,113	3,037
77	25	109.73	1,097.3	1,021.1	1,015.4	10,000	3,000
77.5	25.3	109.84	1,098.4	1,022.6	1,016.5	9,889	2,964
78	25.5	109.95	1,099.5	1,024.1	1,017.6	9,779	2,928
78.5	25.8	110.06	1,100.1	1,025.6	1,018.7	9,671	2,890
79	26.1	110.17	1,101.7	1,027.2	1,019.8	9,563	2,858
79.5	26.4	110.27	1,102.7	1,028.7	1,020.9	9,458	2,823
80	26.7	110.38	1,103.8	1,030.2	1,022.1	9,353	2,789
80.5	27	110.49	1,104.9	1,031.7	1,023.2	9,250	2,756
81	27.2	110.60	1,106.0	1,033.3	1,024.3	9,148	2,723
81.5	27.5	110.70	1,107.0	1,034.8	1,025.4	9,045	2,690
82	27.8	110.81	1,108.1	1,036.3	1,026.5	8,943	2,658

Table 2. Resistance Versus Temperature

°F	°C	Type 12 thermistor	Type 13 thermistor	Type 15 thermistor	Type 17 thermistor	Type 18 thermistor	Type 21 thermistor
72	22.2	11,307	5,654	113,080	22,825	2,546	2,005
72.5	22.5	11,169	5,584	111,680	22,525	2,515	1,983
73	22.8	11,031	5,515	110,300	22,226	2,484	1,962
73.5	23	10,896	5,448	108,960	21,935	2,454	1,941
74	23.3	10,762	5,381	107,620	21,645	2,424	1,920
74.5	23.6	10,631	5,316	106,320	21,362	2,394	1,899
75	23.9	10,501	5,251	105,020	21,080	2,365	1,879
75.5	24.1	10,374	5,188	103,760	20,806	2,336	1,859
76	24.4	10,247	5,124	102,480	20,532	2,308	1,839
76.5	24.7	10,123	5,062	101,240	20,266	2,280	1,819
77	25	10,000	5,000	100,000	20,000	2,252	1,800
77.5	25.3	9,880	4,940	98,800	19,741	2,225	1,791
78	25.5	9,760	4,880	97,600	19,483	2,198	1,762
78.5	25.8	9,643	4,821	96,420	19,232	2,171	1,743
79	26.1	9,526	4,763	95,260	18,981	2,145	1,725
79.5	26.4	9,412	4,706	94,120	18,737	2,119	1,707
80	26.7	9,298	4,649	92,980	18,494	2,094	1,689
80.5	27	9,187	4,616	92,320	18,257	2,069	1,671
81	27.2	9,077	4,583	91,660	18,020	2,044	1,653
81.5	27.5	8,969	4,507	90,140	17,790	2,020	1,636
82	27.8	8,861	4,431	88,620	17,560	1,996	1,619

For complete **Resistance Versus Temperature** tables, please refer to TI.700-11.

For Technical / Application Assistance call your nearest office



8189 Century Boulevard • Minneapolis, MN 55317-8002 • USA
 800-843-5116 • 952-556-4900 • Fax 952-556-4997
 sales@mamacsys.com • www.mamacsys.com

EUROPE

4200 Waterside Centre
 Solihull Parkway
 Birmingham • West Midlands
 B37 7YN • United Kingdom
 01384-271113 • Fax 01384-271114

CANADA

675 Cochrane Drive
 East Tower • 6th Floor
 Toronto • Ontario
 L3R 0B8 • Canada
 905-474-9215 • Fax 905-474-0876

ASIA

1 Fullerton Road #02-01
 One Fullerton
 Singapore • 049213
 65-31581826 • Fax 65-31581826

AUSTRALIA

4 Armiger Court, Unit 2
 Adelaide • S.A.
 5088 • Australia
 08-8395-4333 • Fax 08-8395-4433

MAMAC Systems, Inc., reserves the right to change any specifications without notice to improve performance, reliability, or function of our products.